

\$7.50

Polyvend SuperSeller 2000

Polyvend INC.

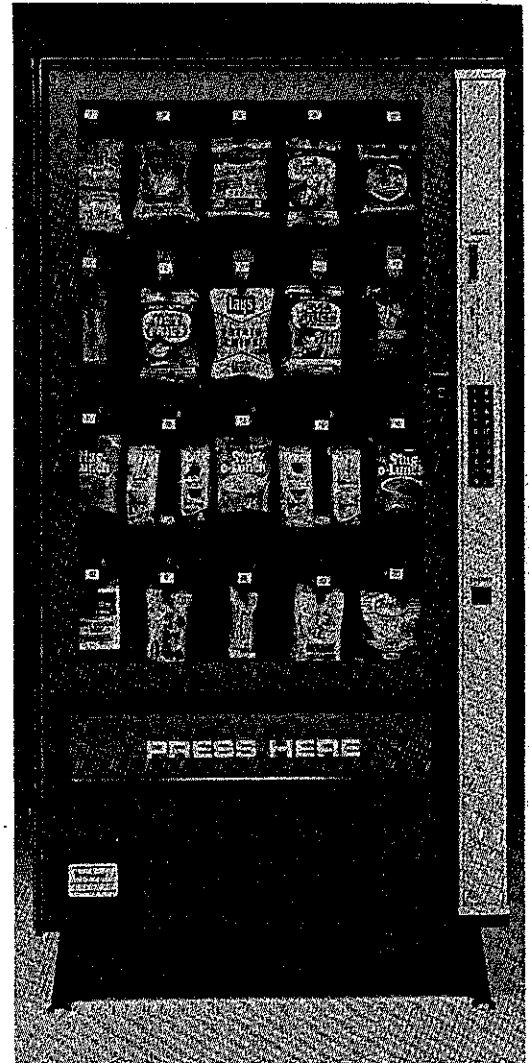

SERVICE MANUAL

SERVICE MANUAL
MODEL SS 2000
AUTOMATIC RACK MERCHANDISER

GENERAL

The Polyvend SS 2000 has been developed specifically for the display rack merchandising market. Each of 20 independent dispensing units may be activated by push button selection after sufficient credit has been established in the coin mechanism.

Each dispenser is readily removable from the front for replacement or repair. Two types of module dispensers (hanging or tray) are supplied for optimum product selection.

SPECIFICATIONS

OVERALL DIMENSIONS:

Height.....72"
Width.....36"
Depth.....32"
Front Clearance (Door).....31"

ELECTRICAL:

Primary.....210 VAC
Secondary.....24 VAC
Current (Primary)....2 AMP

WEIGHT:

Shipping.....538 pounds

CAPACITY:

8 Confectionary (Candy)
Modules.....176 pieces
12 Snack (Chip)
Modules.....144 packet
Total.....320 packet

Note: Polyvend, Inc. is not responsible for faulty or overloaded circuits where Polyvend machines are installed. The exact load imposed by each machine is stated in the related service manual. The sum of all such machines in any particular location will determine the total line load.

NOTE: THIS MANUAL APPLIES TO MACHINES AFTER SERIAL NUMBER 13028

INSTALLATION

GENERAL

Remove shipping carton from around machine by cutting the steel band at the bottom of the carton and push the carton upward.

Check for shipping damage.

Remove keys from envelope in delivery compartment.

Open service door and remove cardboard filler from dispenser assemblies.

Remove tape from sliding door and coin return cup.

Set coin equipment to the desired price levels in accordance with the coin equipment instruction sheet. Coin equipment is installed behind the sliding door on the right-hand inner wall of the product loading compartment.

Plug in numbered motor leads to one of the terminal strips for desired price settings (SEE FIGURE 1).

Save extra fuses, etc. found in the envelopes.

Adjust leg equalizer on the bottom of the machine until the product loading door can be opened and closed freely without binding or rubbing on the cabinet opening. All four equalizers must contact the floor.

Connect to power and leave power on for all tests.

Check alignment and engagement of rack modules.

Check retaining screws on module arms.

Check fit of light tubes, starters, and fuses.

Check operation of door on delivery compartment.

- Check operation of the service door and lock.
- Ensure that all rack module dispensing chains are running free inside their guides.
- Ensure that all confectionary dispensing cups are located firmly on conveyor chain links in the module.
- If modules seem sluggish, (i.e. slow or reluctant to turn), re-check line voltage for voltage drop.

- Load the machine with product. (SEE "Product Loading")
- Check that all rack module arms "click" home.
- Check that number indicator tab assembly is in correct position on each module end to correspond to selector switch.
- Close sliding door on inside right panel. NOTE: The sliding door must be closed before the service door can be locked.

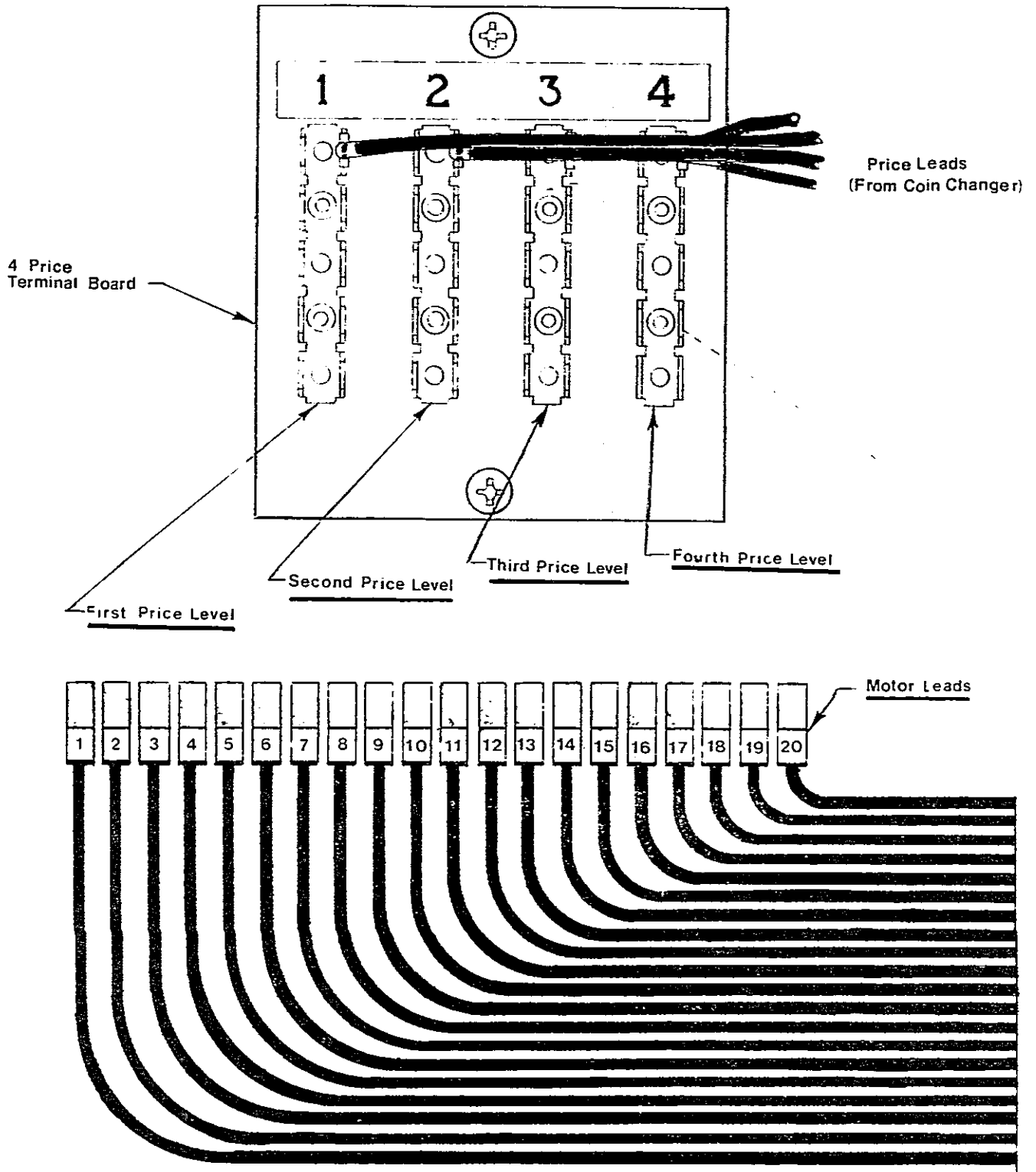

FIGURE 1

PRODUCT LOADING

All product loading of the SS 2000 is accomplished from the front. Using one of the keys provided, open the door to the product loading compartment.

To load, release the latch on each dispenser as shown in FIGURE 3 and pull forward until the slide hits the stop.

FIGURE 3

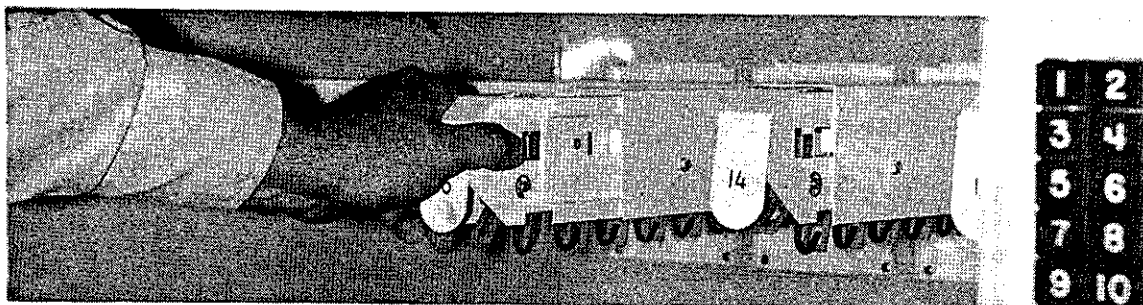

There are three versions of the dispensers.

First to be considered is the wedge type packet hanging dispenser.

WARNING: DO NOT ATTEMPT TO PULL PRODUCT FROM THE BAG DISPENSER AT ANY TIME. SUCH ACTION WILL EITHER JAM THE MECHANISM OR PULL THE WEDGE ASSEMBLIES APART.

Each bag is inserted into a wedge assembly as shown in FIGURE 4. This can be done many ways; however, there is a best way which consists of inserting the bag into the wedge at an angle and sliding the bag until centered in the wedge. Do not attempt to load last position on each chain. Release product by pressing lever up behind bag (FIGURE 4B).

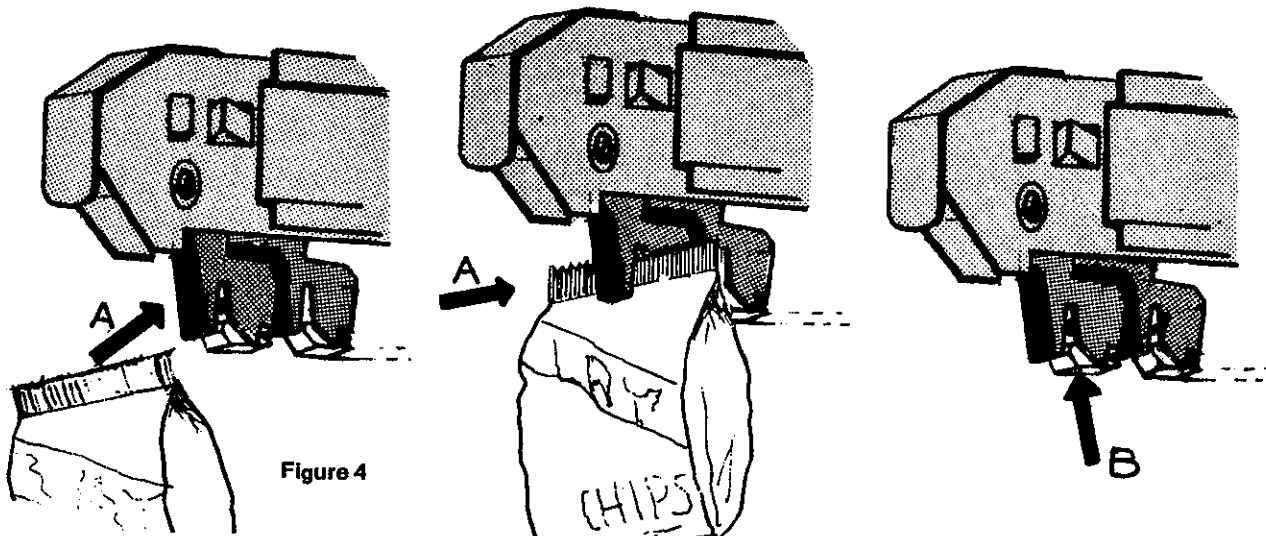

Figure 4



A second type hanging dispenser is the hook chain module. It utilizes the same type module slide but is designed to hold products with a hole pierced in the packet. A hole tab can be purchased that has adhesive on it that sticks to the packet. Using this hole tab makes it possible to easily hang snacks and many other products on the hook chain.

To load the product on the hook dispenser, grasp the product with both hands on the top edges. Push the top of the product wrapper between the retainer and the hook, which will allow the hole in the bag to slide over the hook. (FIG. 5 A)

When a selection is made, the chain advances on the arm. As the chain turns around the front sprocket, the hook swings up and away from the retainer and the bag slides off the hook and falls into the delivery compartment. (FIG. 5 B)

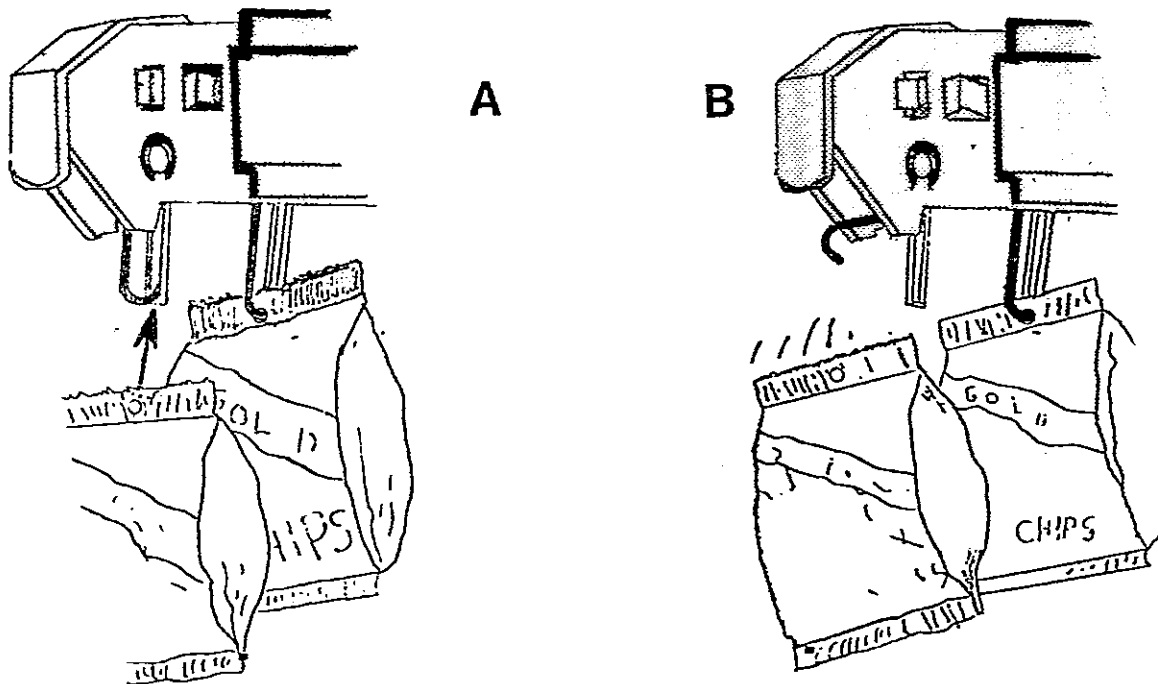

FIGURE 5

The third type dispenser to be considered is the candy (confectionary) module. Load the candy module by dropping the products into the individual dispensing cups. Since the dispensing cups rotate left to right, the product on the left should face forward, and the product on the right should face backward to assure proper fronting (SEE FIGURE 6).

With all dispensers, slide the loaded unit back into the machine until the latch snaps soundly into place.

FIG.6



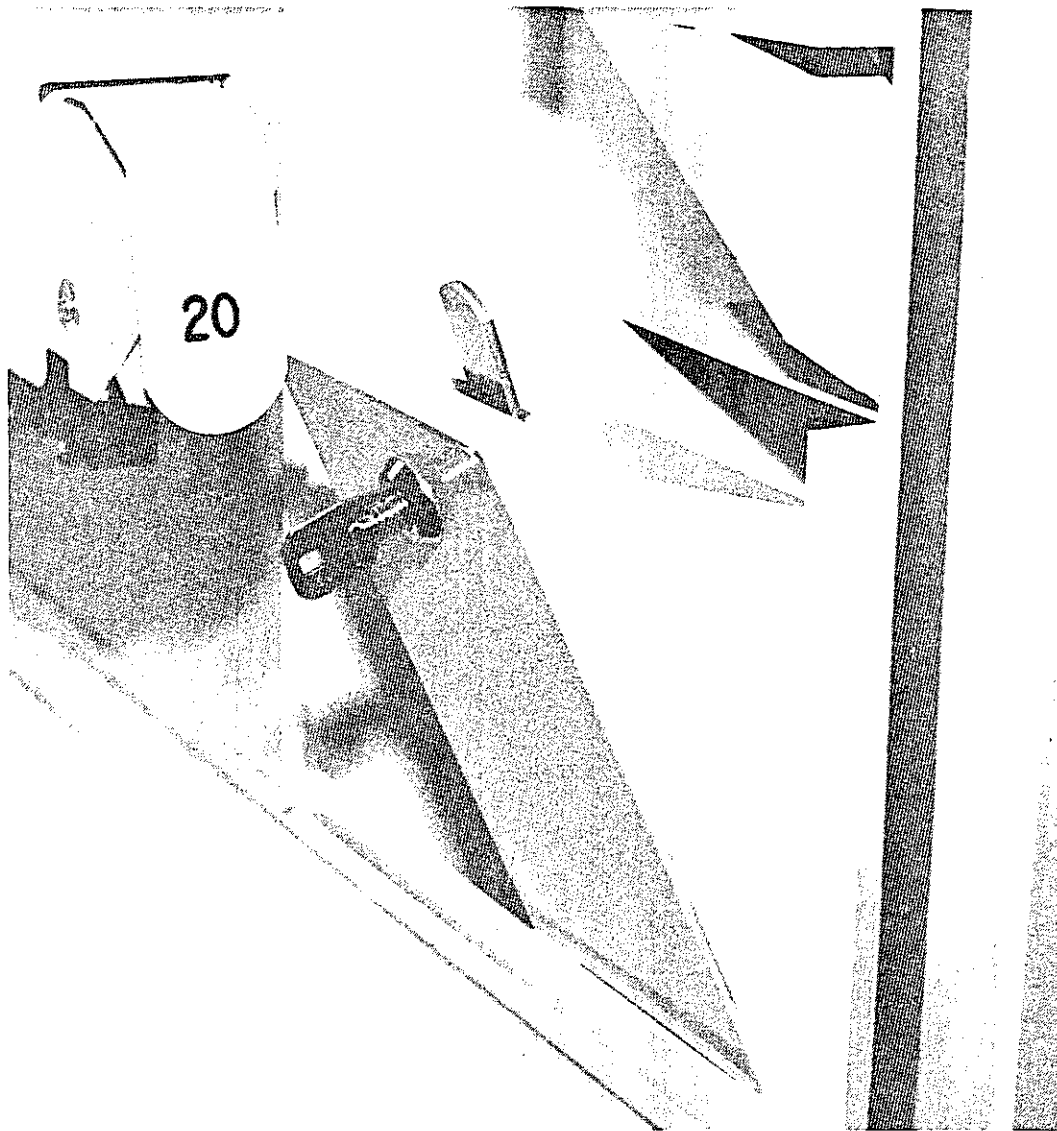

FIGURE 7

COIN COLLECTION

The coin bank is located in the product loading compartment in the right-hand corner as shown in FIGURE 7 . A key is supplied to open this lock. Insert the key, press in and rotate $\frac{1}{4}$ turn counterclockwise to unlock the bank. Allow the top of the bank to tilt to the left until it can be lifted out. Remove the coins and replace by reversing the procedure.

DISPENSERS

Polyvend^{INC.}
CONWAY, ARKANSAS



WEDGE MODULE

FIGURE 8 illustrates the wedge chain dispenser used in the SS 2000. It consists of:

- (1) Motor Assembly
- (2) Module Arm
- (3) Rack Module & Slide Assembly

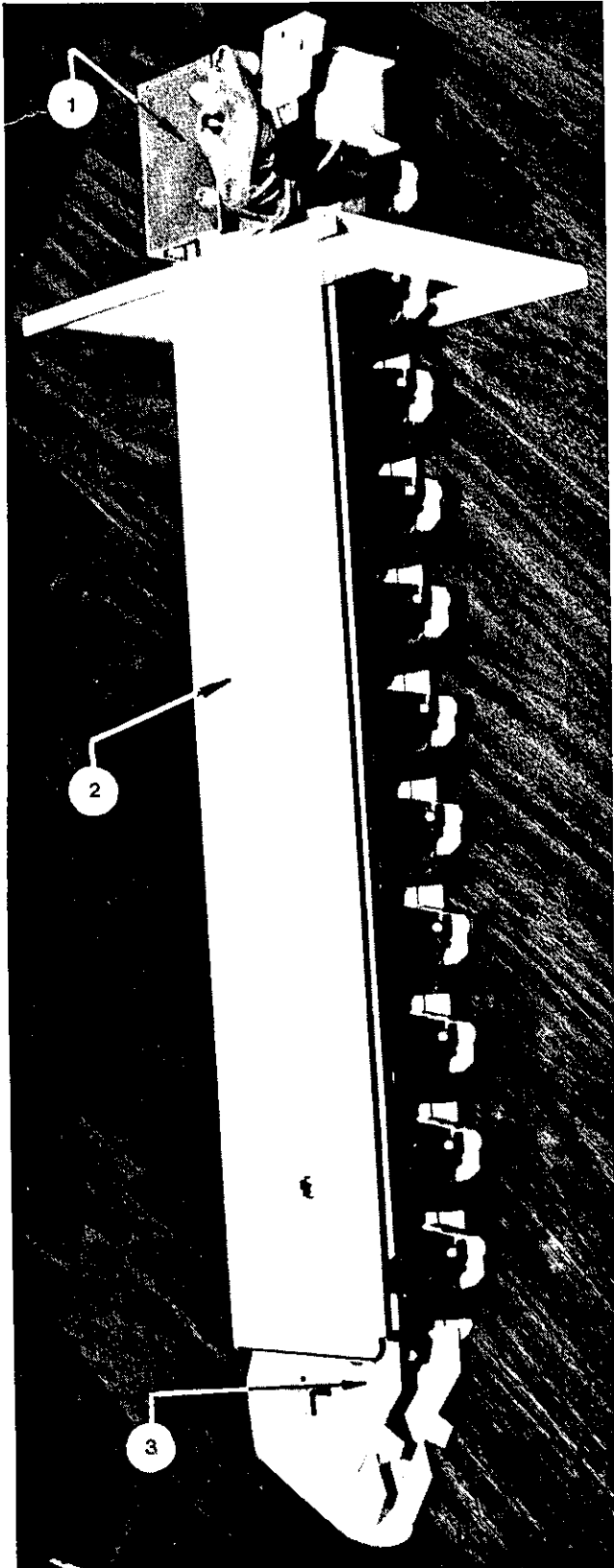

When a product selection is made, an electric signal from the selector switch starts the motor, and a carry over circuit through the make-then-break switches of the motor completes the 180° rotation advancing the dispensing chain one step. As the leading chain segment moves around the front sprocket, the hook of the following segment acts as a lever to activate the white slide and lifter of the front segment, forcing the spring loaded cylinders upward (SEE FIG. 4B). This upward movement releases the wedged grip maintained on the merchandise bag, and the bag drops to the delivery compartment, completing the vend.

In a previous section on loading, a warning was given about pulling products out of the dispenser. If a brute force pull in a downward direction is used, it will cause the metal cylinders to seat against the plastic dispenser chain segment. The product cannot be released and the module may hang in cycle which causes the machine to be inoperative. A good indication of someone pulling on the bags is chain parts found laying loose in the machine. Even if less force is used, tolerances will be changed, causing eventual failure of the dispensing chain.

The correct way to remove product is actually easier, and consists of pushing up on the white-colored release lever immediately behind the product. This causes the product to fall into your hand without harming the dispenser.

There is a particular type of bag made of glassine material that cannot be vended with the Polyvend wedge chain. This is a coated material that covers the metal cylinders with wax causing the bags to fall out freely.

FIGURE 8
(WA THRU WN)

Occasionally, dispensing chains must be replaced or repaired. These chains are timed on installation and must be removed with care. FIGURE 10 shows the sequence of operations to accomplish this task.

- Release the latch on the dispenser and pull slide out to its stop. (FIGURE W A)

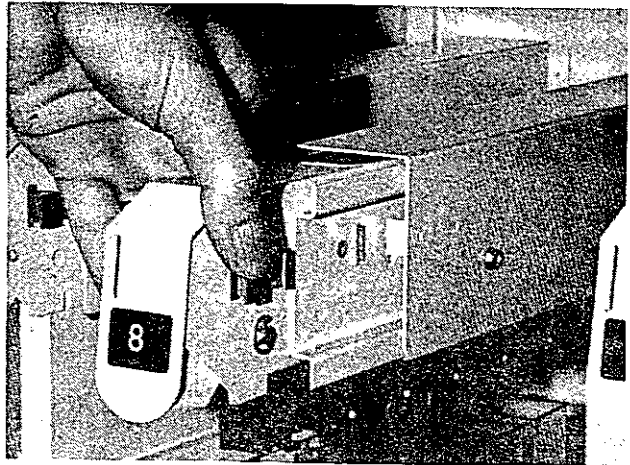
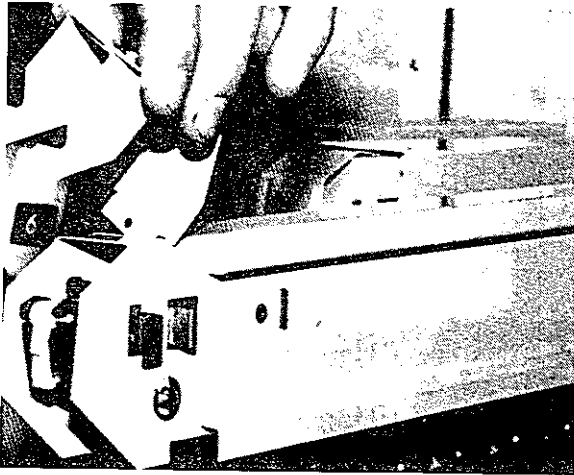

Remove the dispenser number and price cover. (FIGURE WB)

- Remove the screw from the side of the dispenser (FIGURE WC) which serves as the stop and pull slide from the machine.

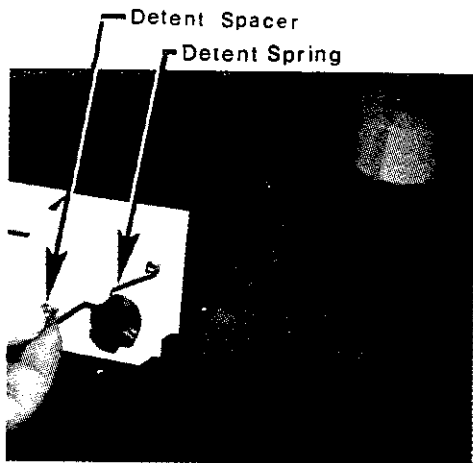
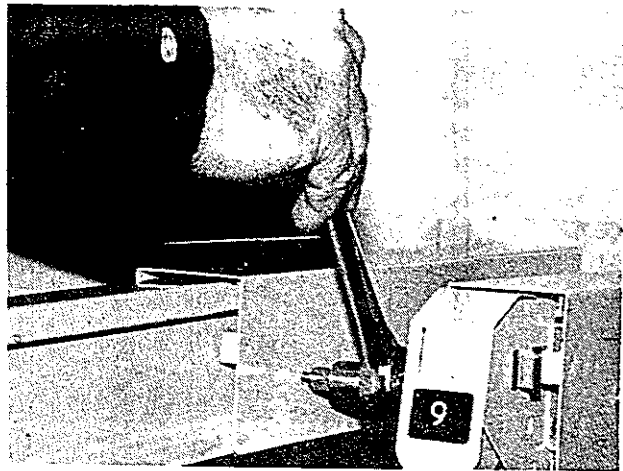

- Release the detent spring by pushing the flat end down and pulling it out from under the detent spacer. (FIG. WD)

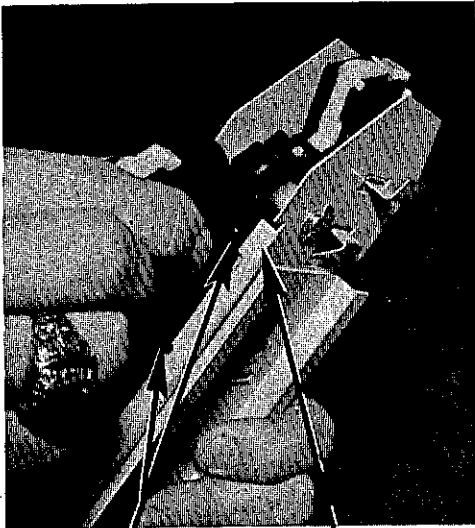

Support Pin Chain Support

- Point front end of slide up and grasp the chain with thumb and fingers. Pull the chain support pin up and over the chain support slide while rotating the chain backward to normal rotation. Repeat until eight (8) pins are on top of the slide, which will allow enough slack to unhook the chain. (FIG. WE)



- Unhook chain by grasping one link near the support pin and the next link near the snap connector - then gently twist the chain until it snaps loose. (FIG. WF)

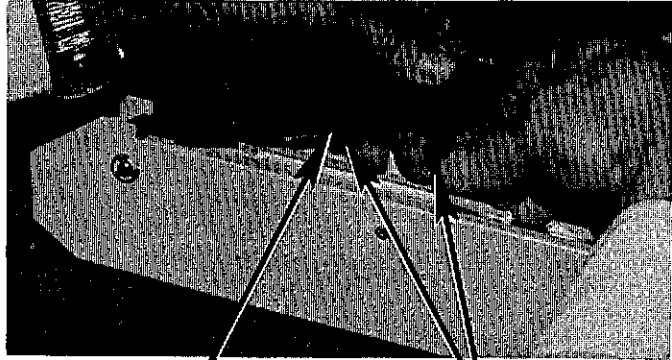

Support Pin Snap Connector

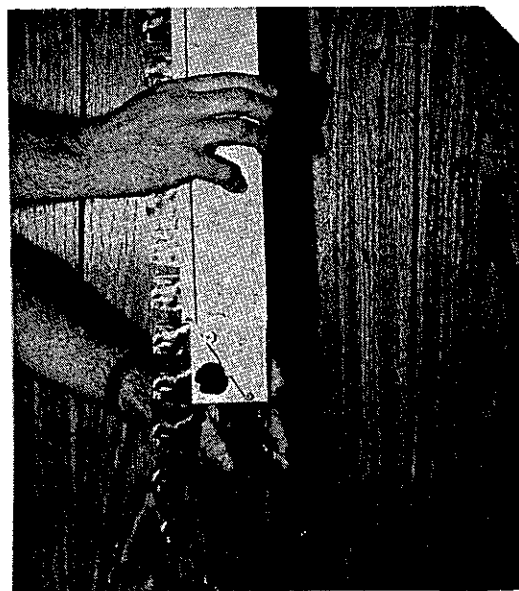

- Hold slide vertical with the front end up, and the chain will fall free of the inner portion of the slide (FIGURE WG)



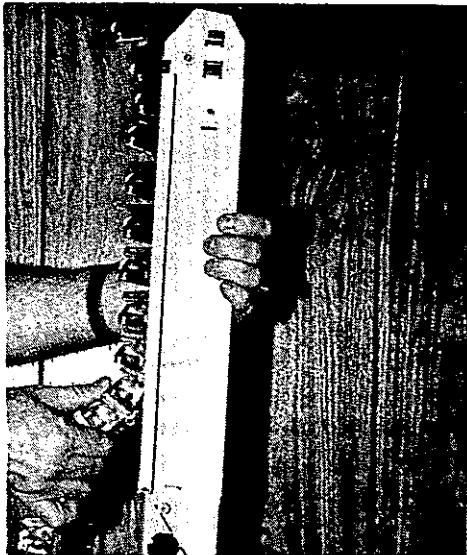

Still holding slide vertical, lift bottom of chain outward and away from the slide. Push upward. The chain should easily slide free. (FIGURE WH)



WEDGE ASSEMBLY REPAIR (FIGURE WI)

To repair the assembly and replace damaged components, remove the chain and snap out the damaged link.

This link is made up of the basic chain housing segment (Black), a cylinder lifter (White), a slide (White), two cylindrical wedge components and a compression spring. (FIGURE WI)

To disassemble, hold the link between both hands and push the cylinder lifter stub shafts outward with both thumb nails. It will pop out (retain with fingers) and may be removed. Next, the slide may be removed. Take care the compression spring isn't lost as the slide is removed. Now, the spring will fall free and the cylindrical wedge components will follow when the link is inverted. When reassembling the lifter, be sure the "flat" edge is against the cylindrical wedge and not against the slide.

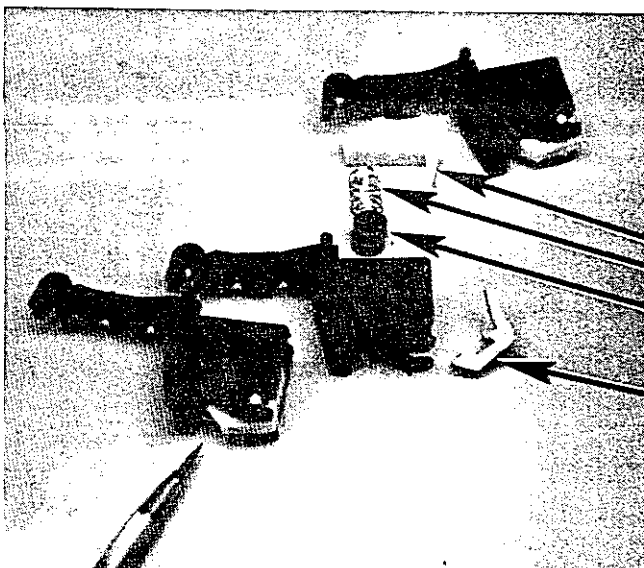

All that remains is to reassemble using replacement parts as necessary. When the link has been repaired, snap it back on the chain.

- SLIDE
- SPRING
- CYLINDRICAL WEDGE
- LIFTER

FIGURE WI

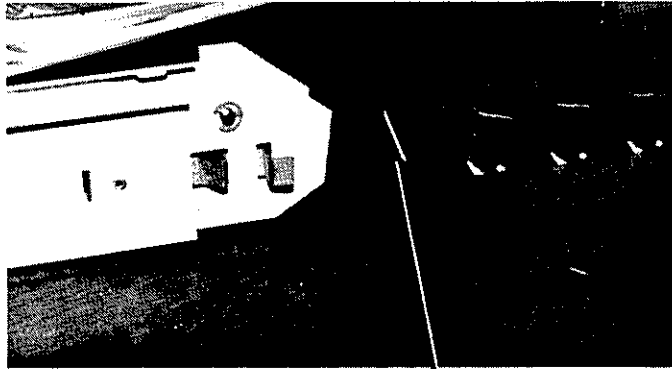

Snap Connector

- To replace chain, lay dispenser on it's top and insert the chain end through the front of the module. (The snap connector end must be inserted from the front as shown or chain rotation will be wrong). Continue pushing the chain through the dispenser until equal lengths of chain are sticking out each end.(FIG. WJ)



To time the chain, re-engage the detent spring by turning the sprocket to the detent position and pushing the detent spring end under the detent spacer. Align a support pin with the back edge of the module. (During the next step, be careful NOT to move the chain forward or backward as this would misalign the support pin and therefore chain timing would be wrong). (FIG WK)

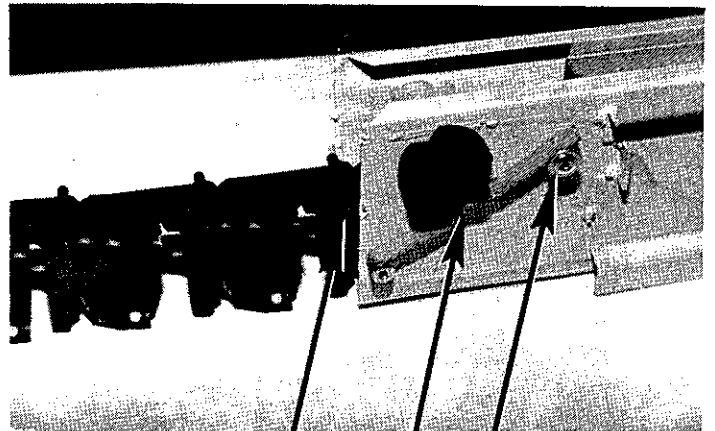

Support Pin

Detent Spacer
Sprocket Detent

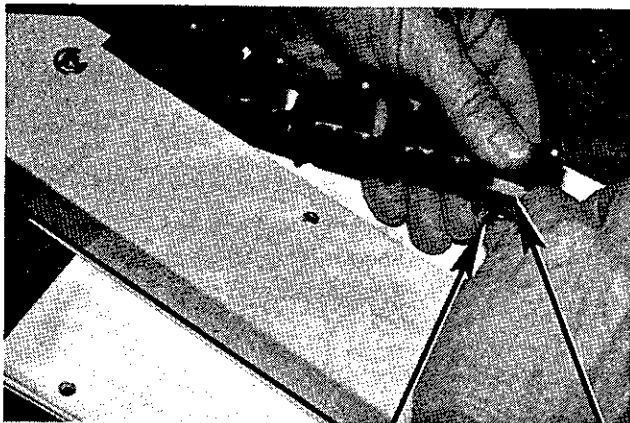

Snap Connector

Slide

- Grasp both ends of the chain and pull it over the bottom of the module. Push the white color slide out of the way and push the snap connector onto the support pin. (FIG. WL)



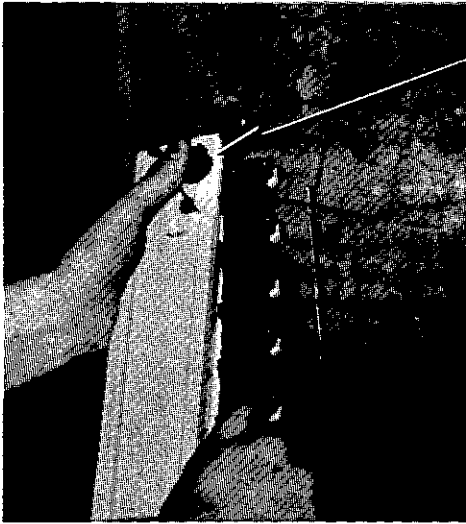

Detent
Sprocket

- To place the chain guide pins in the chain support slide, grasp the chain with one hand and rotate it in the direction of normal rotation, while holding the detent sprocket in with one thumb. (FIGURE WM)



- Continue pulling the chain until 3 complete revolutions have been made. With the detent spring in the detent position, the leading chain segment will be in the position shown if the timing is correct. (FIGURE WN)

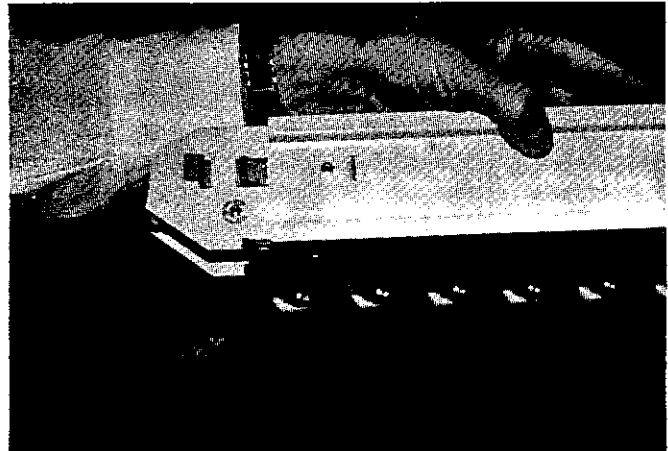

CANDY MODULE (CONFECTIONARY)

FIGURE 9 (CA THRU CP)

The candy dispenser slide assembly is removed from the machine in the same way that the chain slide assembly is removed. Just withdraw the stop screw and slide the assembly out of the machine.

CUP AND PLASTIC CHAIN REMOVAL

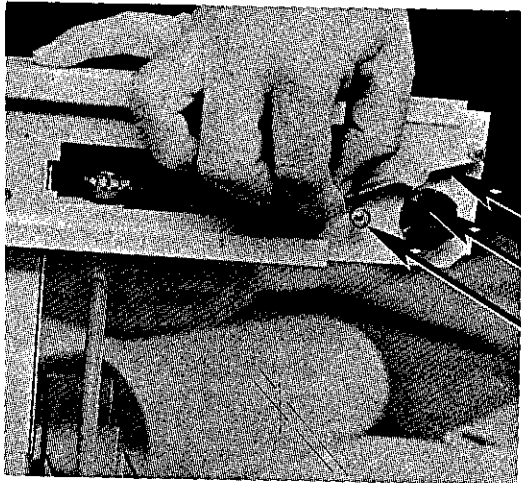

Detent Spring

Sprocket Detent

Detent Spacer

Release the detent spring by pushing the flat end away from the detent spacer and pulling the spring out from under the spacer. (FIGURE CA)





Pull upward on the cups
and they will snap loose.
After all cups are removed,
the chain can be removed by
twisting the chain until
it unsnaps. (FIGURE CD)

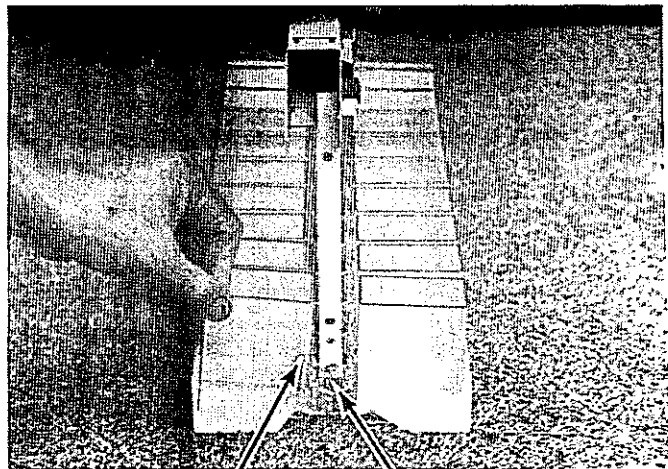

Cup Connector — Chain Pin

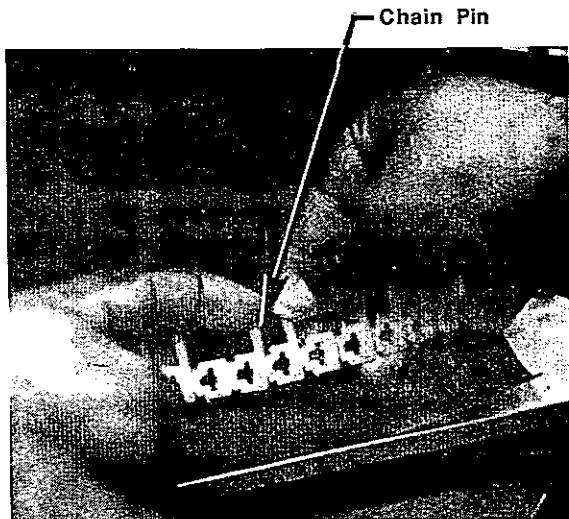

After all cups are removed,
the chain can be removed by
placing a finger behind the
top pin on one link while
pushing the pin on another
link with a thumb. The chain
will snap apart. All damaged
links can be replaced with
new ones. (FIGURE CE)



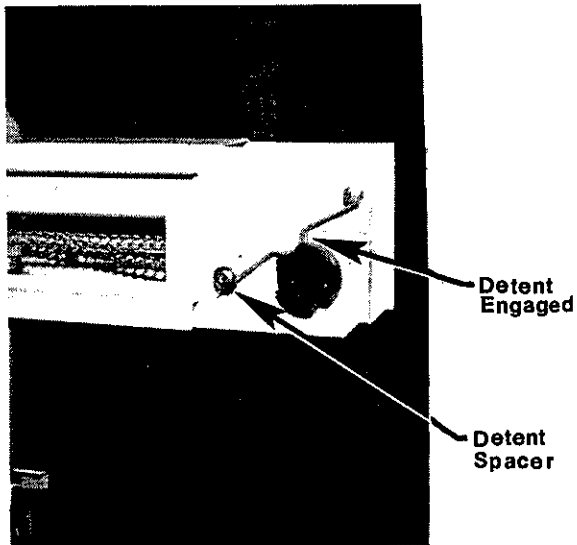

After repairing the chain, reassemble all components, making sure there are 44 cup retainer links and 22 plain links. Then, to reassemble, turn the sprocket to the detent position and reengage the detent spring by pushing the spring end around and under the detent spacer. (FIG. CF)



Place the chain around the front sprocket and align a pair of cup pins opposite each other, as shown. (This will assure proper timing of the cups when the chain is snapped together.) Without moving the front sprocket, pull the chain tight and wrap it around the back sprocket. (FIG. CG)

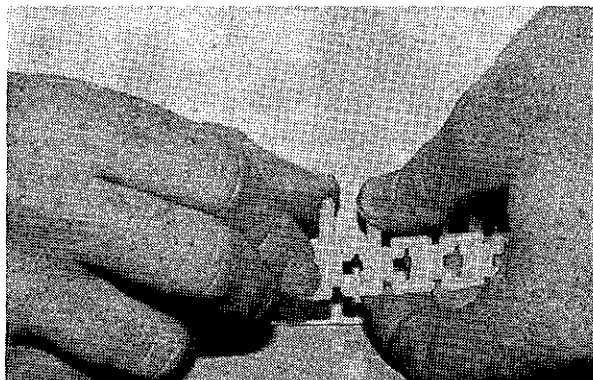
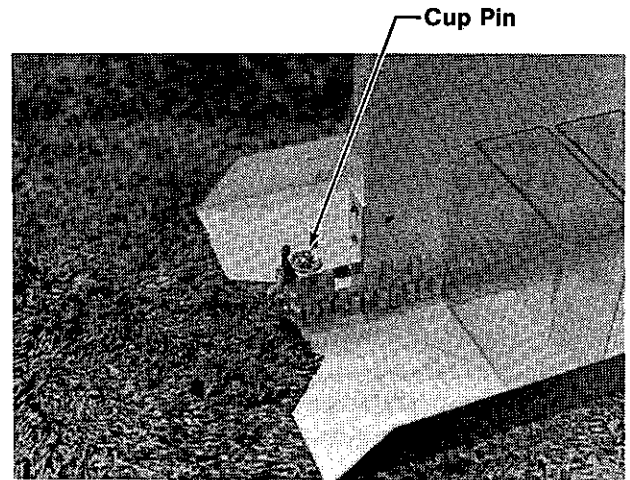

With the detent spring engaged, and the cup pins aligned opposite each other, snap the chain together. (FIG. CH)



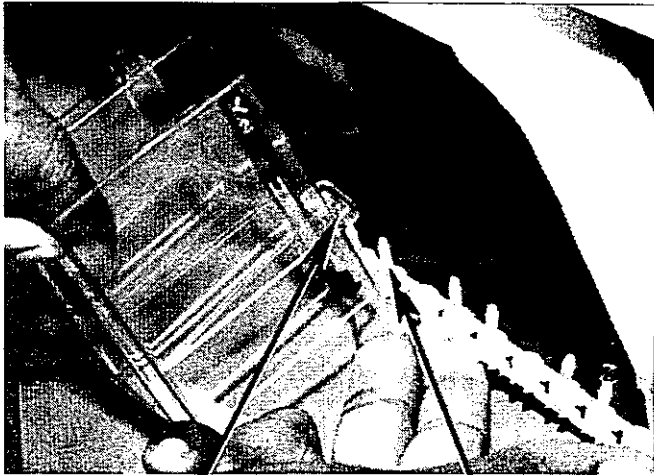

— Cup Mounting Tab — Chain Pin

To replace dispensing cups, snap the cups back on the chain pins. For easier installation, place two fingers under the chain while pushing the cups on with the other hand. Be sure the cups are pushed all the way down on the chain. (FIGURE CJ)



After all cups are replaced, check for proper timing. (The module is timed correctly when the detent spring is engaged and the front cups are parallel to each other. (FIG. CK)

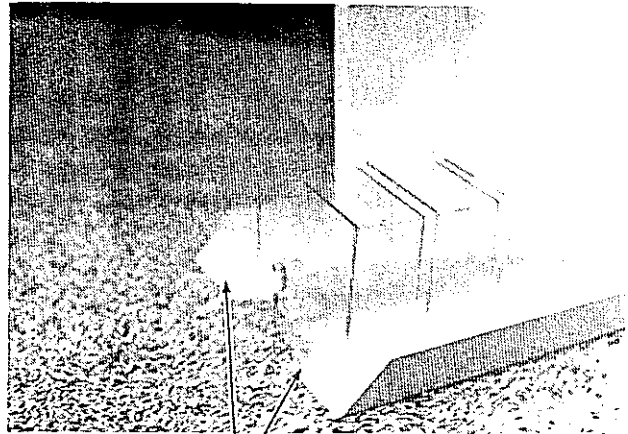

— Correct Timing

Re-install the candy module in the machine and tighten the stop screw on the side of the module arm. (SEE FIGURE CA)

LADDER CHAIN REMOVAL AND REPLACEMENT

To replace the metal ladder chain, pry the drive sprocket off the vertical shaft. The chain will hang free from the back drive sprocket.
 (FIGURE CL)

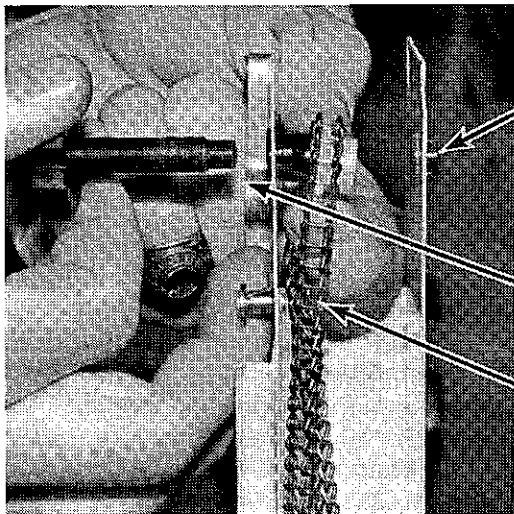
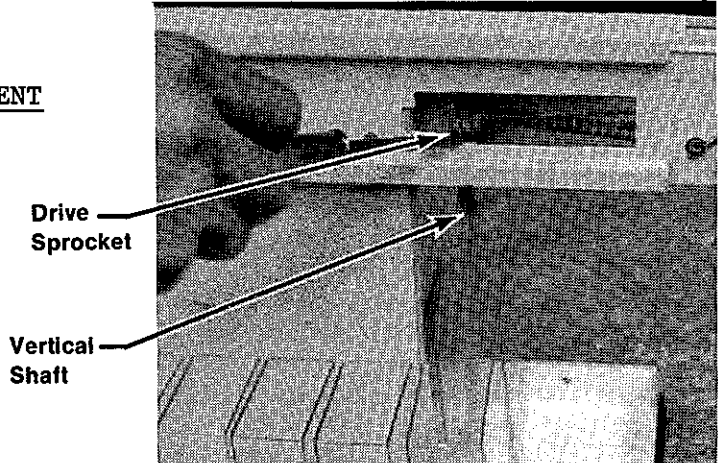

To remove the chain from the sprocket shaft, pull the back sides of the slide module apart, allowing the sprocket shaft to slide out of the bushing. The chain will drop off the shaft. Place the new chain on the back drive sprocket and push the sprocket shaft through its bushing. (FIGURE CM)

To time the module, position the cups so the two front cups are parallel, and be sure the detent spring is engaged. (FIGURE CN)

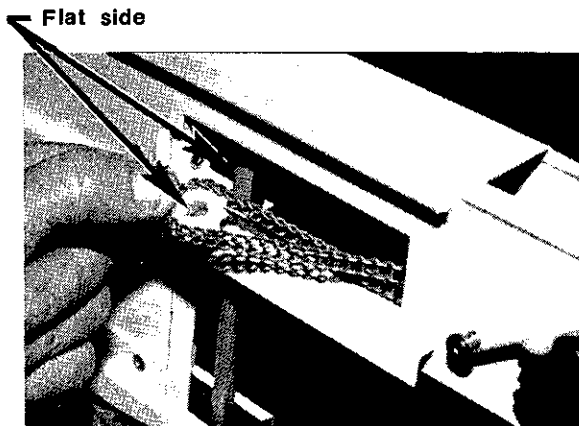
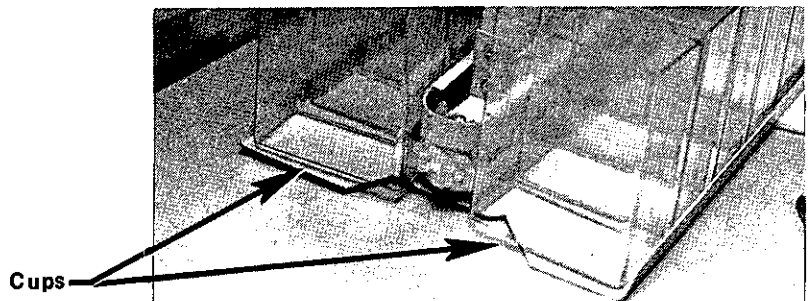

To re-install the drive sprocket on the vertical shaft, hold the sprocket so the flat side of the sprocket shaft hole is facing the flat side of the shaft. Pull the chain through the slide access hole and "twist" the chain 1/4 turn and place it on the sprocket. (The chain must be "twisted" as shown or the cups will rotate backward. (FIG. CO)

with the chain around the sprocket, place the sprocket on the vertical shaft. Be sure the sprocket is pushed down all the way on the shaft. (FIGURE CP) 

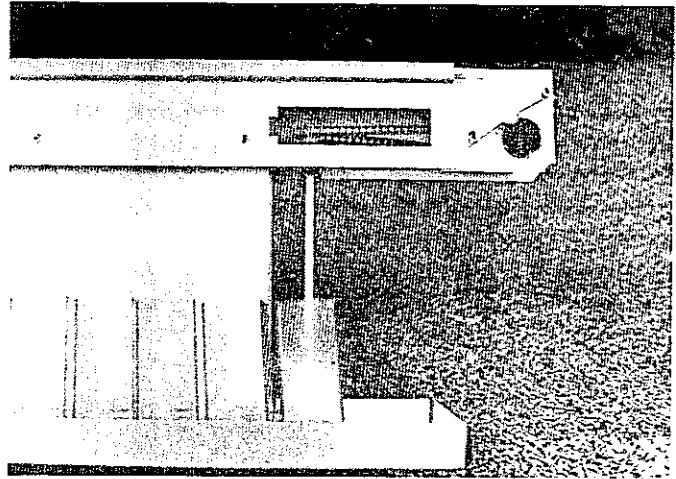

Reinstall the module in the machine, tighten the stop screw, and cycle the machine 3 times. If the timing is not correct or if the module operates backward, repeat steps CL, CN, CO and CP.

NOTES

HOOK DISPENSERS

The hook dispenser is ideal for products that have a hole pierced in the packet. A hole tab can be purchased that has adhesive on it that sticks to the packet. Using this hole tab makes it possible to easily hang snacks and many other products on the hook chain.

If it becomes necessary to replace or repair these chains, follow the sequence of operations in FIGURE 10 (HA THRU HL).

Release the latch on the dispenser and pull slide out to its stop (FIGURE HA). →

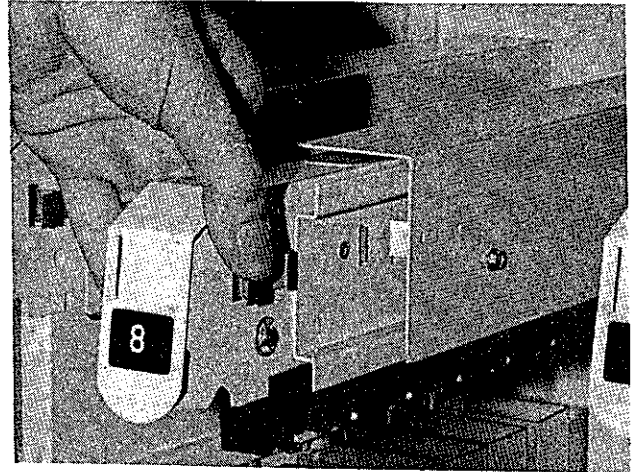
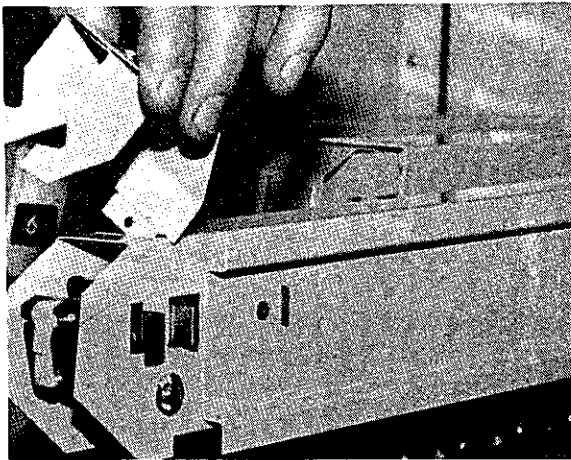

← Remove the dispenser number and price cover (FIGURE HB).

Remove the screw from the side of the dispenser (FIGURE HC) which serves as the stop and pull slide from the machine. →

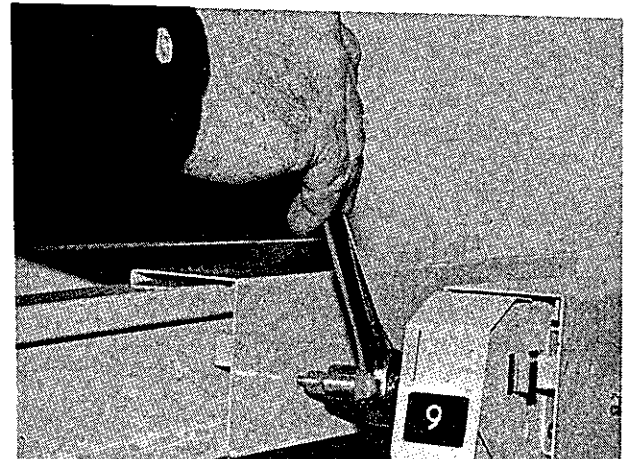
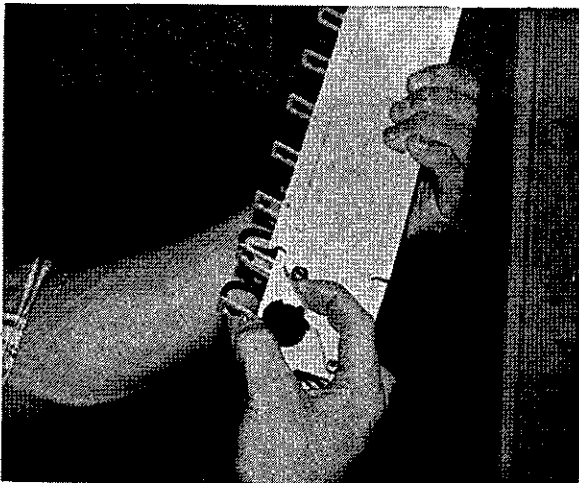

← Release the detent spring by pushing the flat end away from the detent spacer and pulling it from under the spacer. (FIGURE HD)

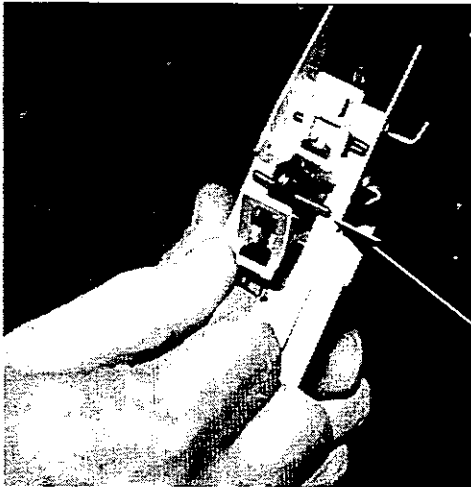

Hold the front end of slide up with one hand and grasp the chain hook with the other hand. Pull the chain support pin up and over the chain support slide while rotating the chain opposite to normal rotation. Repeat until eight (8) pins are on top of the slide, (this will allow enough slack to unhook the chain.) (FIGURE HE)



Support Pin

Unhook the chain by laying the slide module on a work surface with the front end pointing right. Place left thumb under a support pin while placing fingers on top of the other end of the support pin. Grasp gray colored retainer link with right hand and gently twist the chain until it unsnaps. (FIGURE HF)



Hold slide vertical with the front end up, and the chain will fall free of the inner portion of the slide. (FIGURE HG)



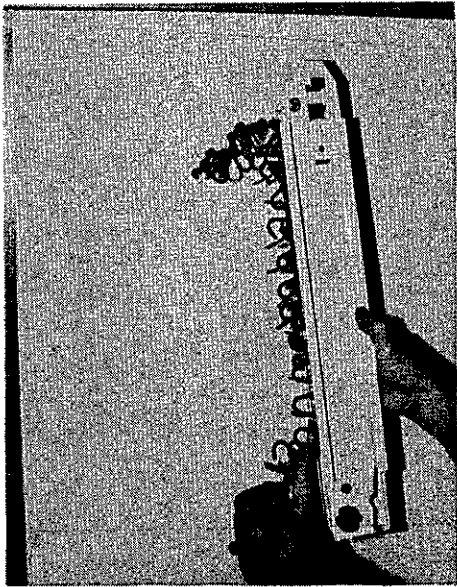

Still holding the slide vertical, lift bottom of chain outward and away from the slide. Push upward. The chain should easily slide free. (FIGURE HH)



After repairing chain, reassemble all components, making sure the chain has 28 of each link. (28 chain links, 28 plain links, and 28 retainer links.)

To replace chain, lay module on its top, reengage detent spring by turning the detent sprocket to the detent position and then pull the spring up and over the detent spacer. Route the chain through the back of the module with the hooks pointing forward as shown. Continue pushing the chain through until equal lengths are sticking out both ends and a support pin is even with the end of the module. (FIGURE HI)

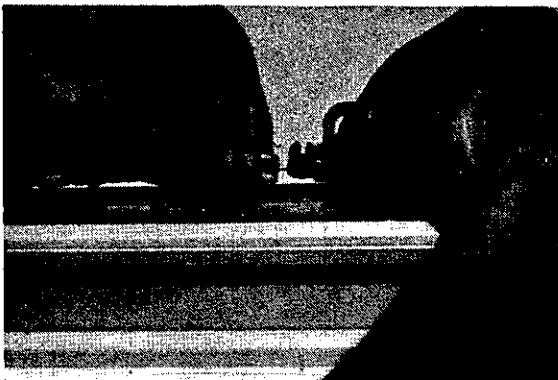
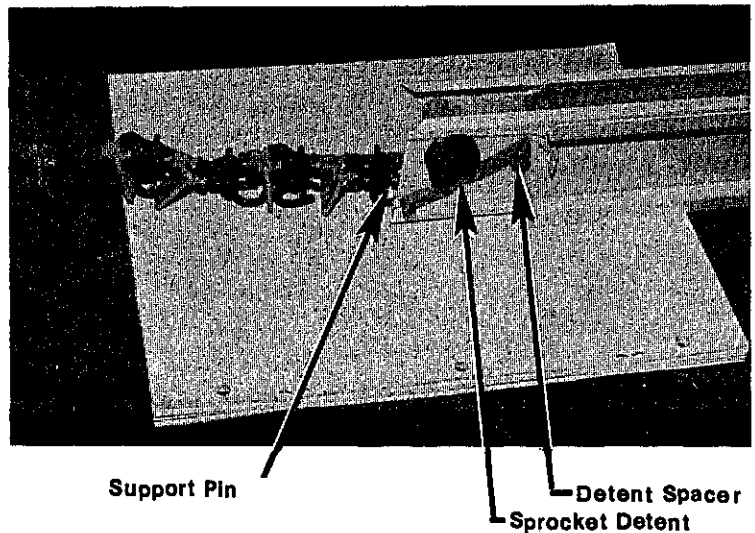

To properly time the chain, keep a support pin even with the back of the module, while pulling the chain ends up and over the module. Place the snap connector on the chain slide, then press the gray link into the snap connector. (FIGURE HJ)





Grasp the chain with one hand while holding the module with the other hand. Place thumb on sprocket to prevent it from coming out of the bushing and pull the chain in the direction of normal rotation. This will reengage the chain support pins in the chain slide. (Do not rotate the chain backward to normal rotation as this would break the support pins.) (FIG. HK)

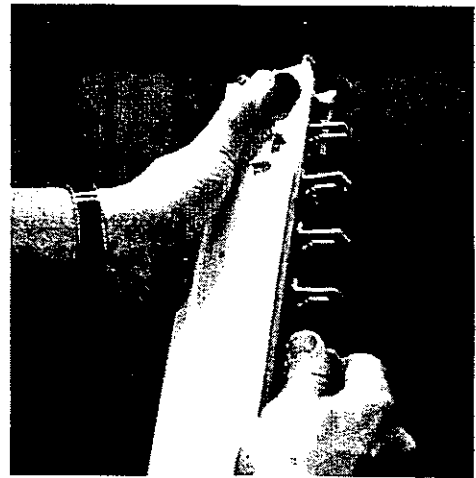

Continue pulling the chain until three (3) complete cycles have been made. If the timing is correct, the chain will be in the position shown when the detent spring is in the detent position. (FIGURE HL)

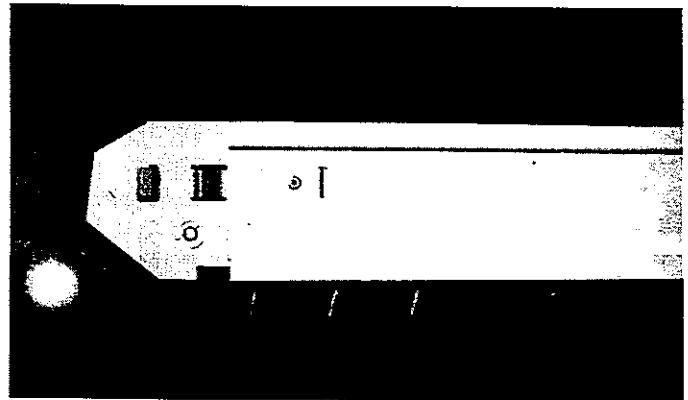

SELECTOR SWITCH

The 20 button selector switch is mounted inside the right front of the product compartment behind the sliding electrical compartment door. It may be removed by backing out four screws and disconnecting it from the control box.

PRODUCT DELIVERY COMPARTMENT

This sub-assembly, including the "push" plastic door, may be removed from the front of the machine thru the product compartment. This may be accomplished as follows:

- Remove product compartment bottom. (5 screws)
- Remove left panel over delivery compartment. (4 screws)
- Remove #17, 18 and 19 dispenser motor assemblies.
- Remove the right side deflector. (2 screws)
- Remove 4 screws on the front inside edge of the delivery compartment.
Note: Support the compartment while removing the last screw to prevent dropping.
- Lift compartment up and turn slightly to remove through the product compartment door.
- Reverse procedure to replace.

REAR ACCESS COVER (DOOR)

A large access cover is provided on the rear of the SS 2000. Its major purpose is to permit access to the wiring harness in the rear of the machine. To remove it use one of the keys provided. Unlock it and lift off. (While pulling outward with key.) CAUTION: Do not allow door to fall freely as this could result in damage to the rear door.

2247

VEND OPERATION

The Four Price Merchandiser's basic vending operation is depicted below:

- A-Depositing coins establishes credit circuits (1 to 4) in the coin mechanism. The ones established are determined by the price setting and amount of coins desposited.
- B-When a selection button is depressed and sufficient credit is established for that price setting in the coin mechanism, the corresponding price line circuit is completed through the coin mechanism and terminal board to the dispense motor selected.
- C-The dispense motor starts its rotation which actuates its snap-action switches.
- D-The inside (#1) motor switch breaks the series circuit to the selector switch and makes one side of the 24 volt circuit to the motor coil.
- E-The outside (#2) motor switch breaks line 6 to the coin mechanism - clearing it and makes the other side of the 24 volt circuit to the motor coil.
- F-The dispense motor rotates 180° until the motor switches are de-actuated by its cam. The product is delivered and the series circuits to the selector switch and line 6 (crem coils) of the coin mechanism are again made ready for the next vend.

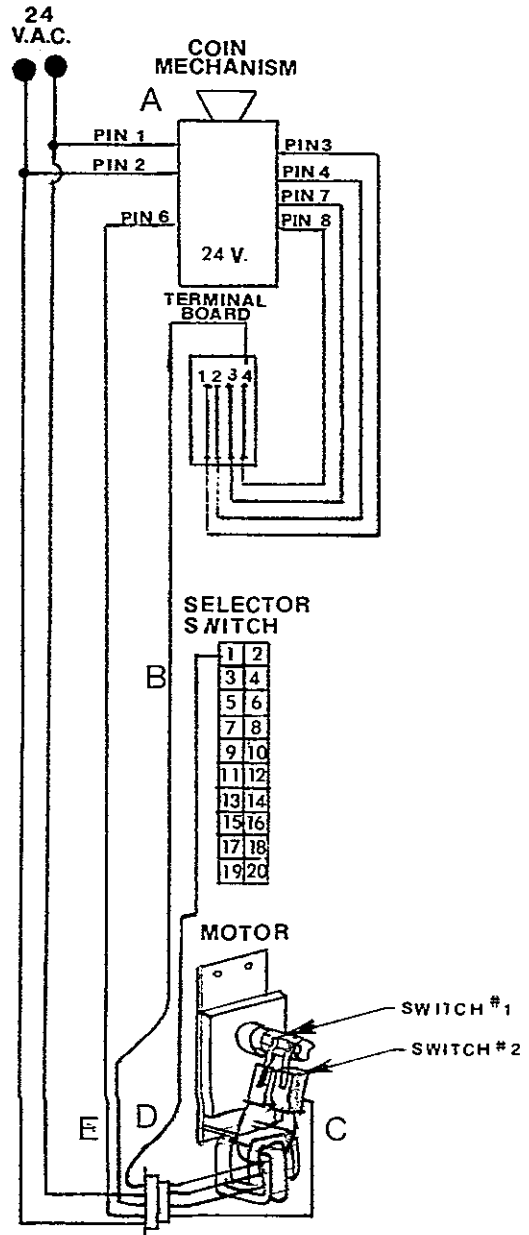
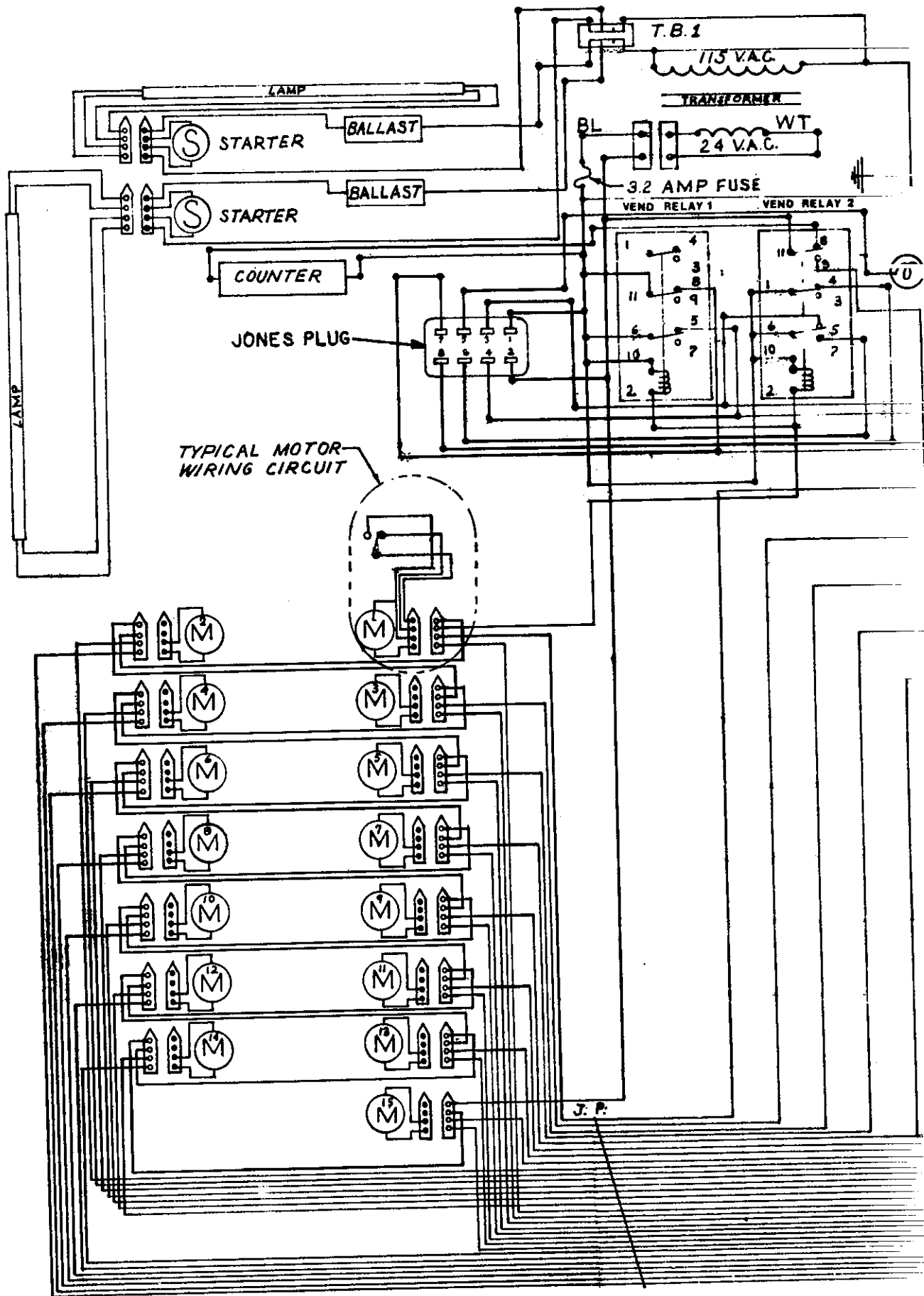
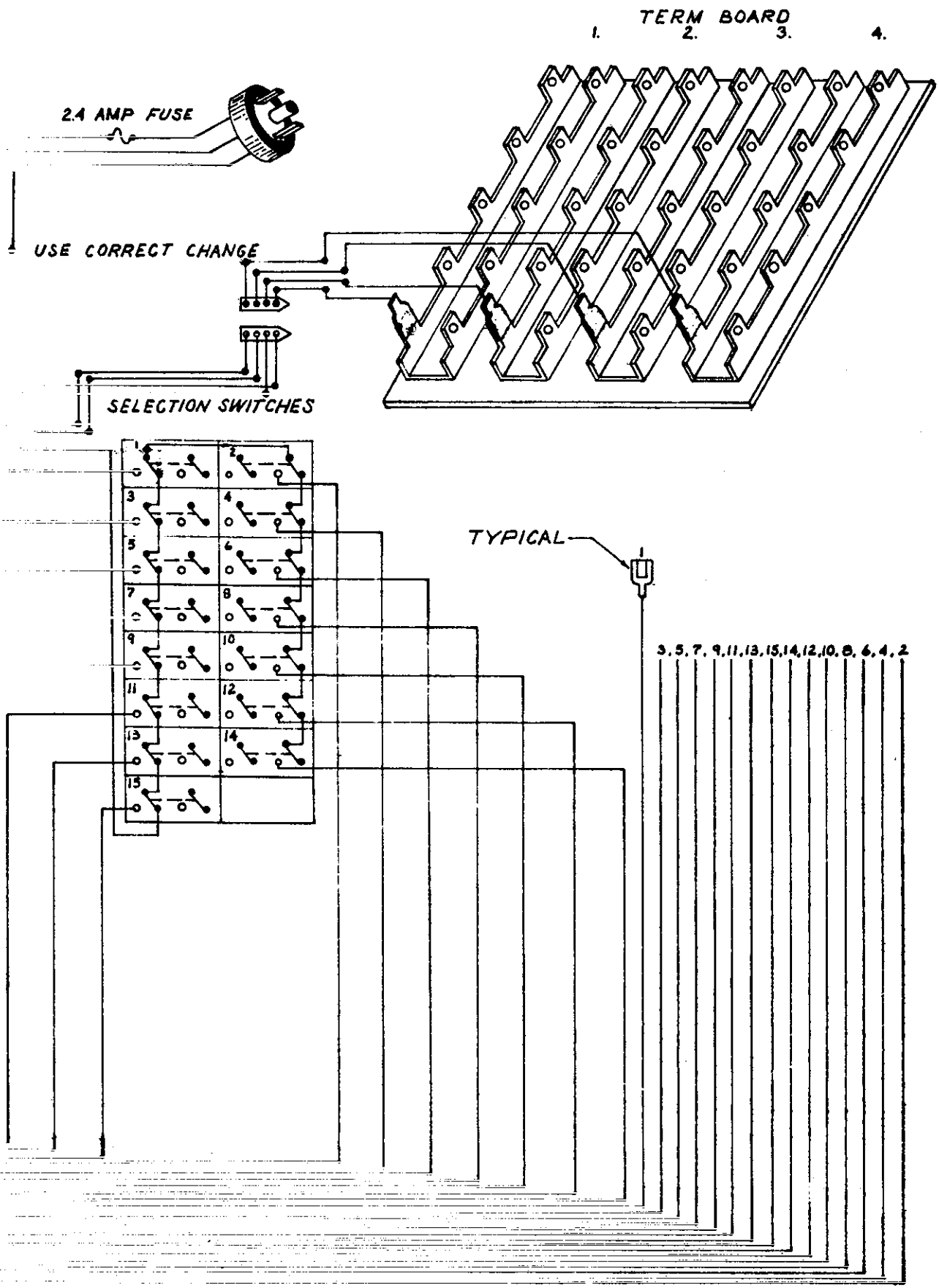

Fig.1



NOTE:
RELAYS SHOWN IN THE DE-EN



TERM BOARD

1. 2. 3. 4.

2.4 AMP FUSE

USE CORRECT CHANGE

SELECTION SWITCHES

TYPICAL

3, 5, 7, 9, 11, 13, 15, 14, 12, 10, 8, 6, 4, 2

REVERSED POSITION

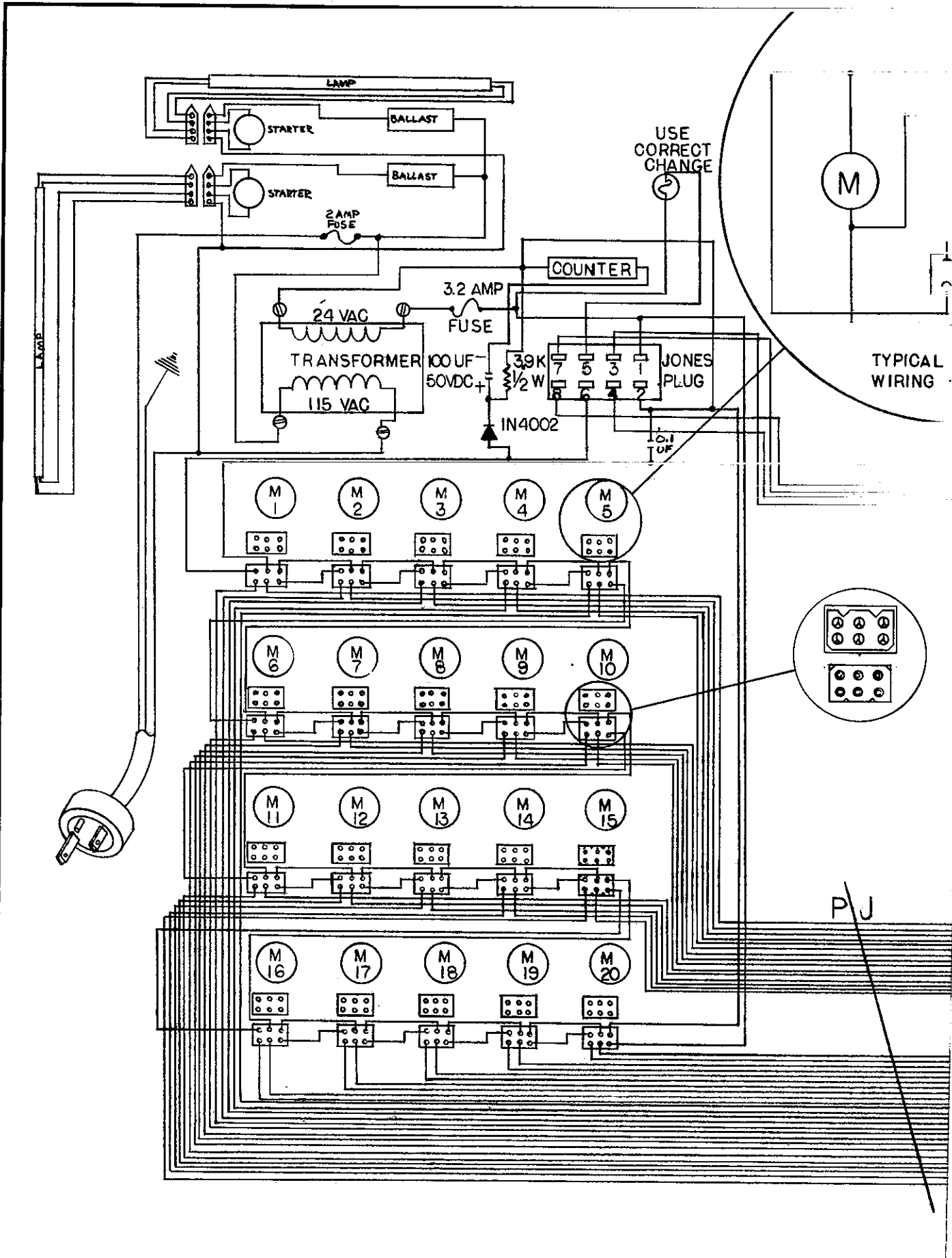

1	PROD. RELEASE (2-286)	1046	DLG	7-10-78	R
REV.	DESCRIPTION	S.D. NO.	BY	DATE	W/m/r

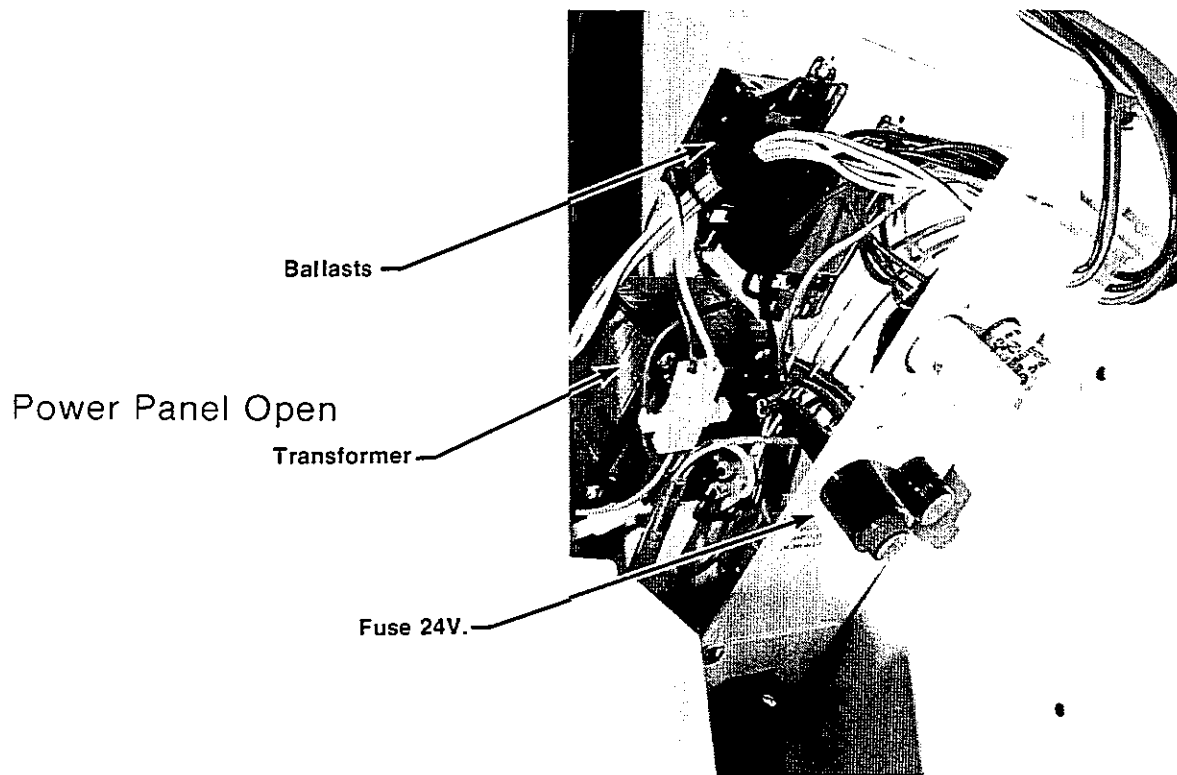

Ballasts

Power Panel Open

Transformer

Fuse 24V.

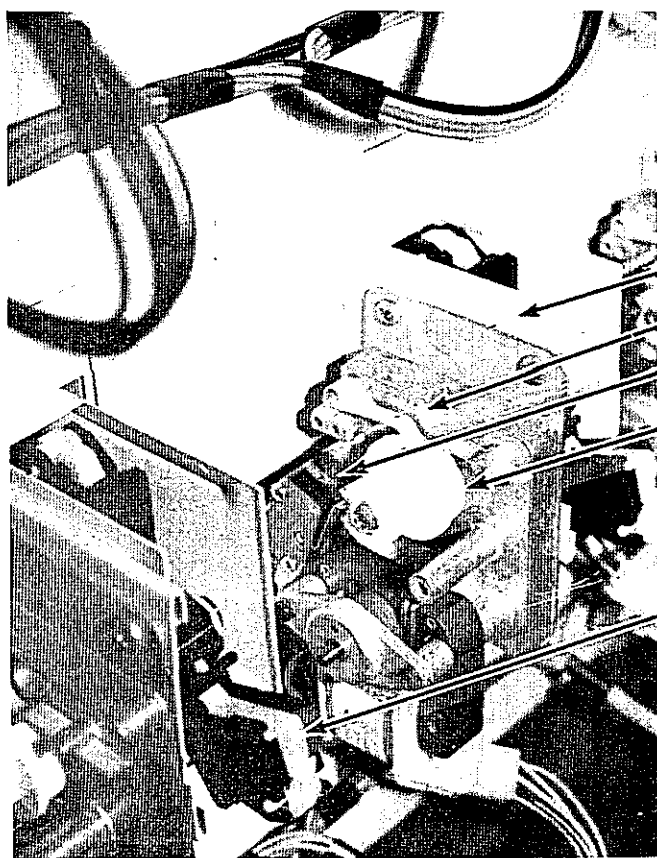

Motor Assembly

Detent Spring

Switches

Cam - 180°

Dispenser Chain

MOTOR DETAILS

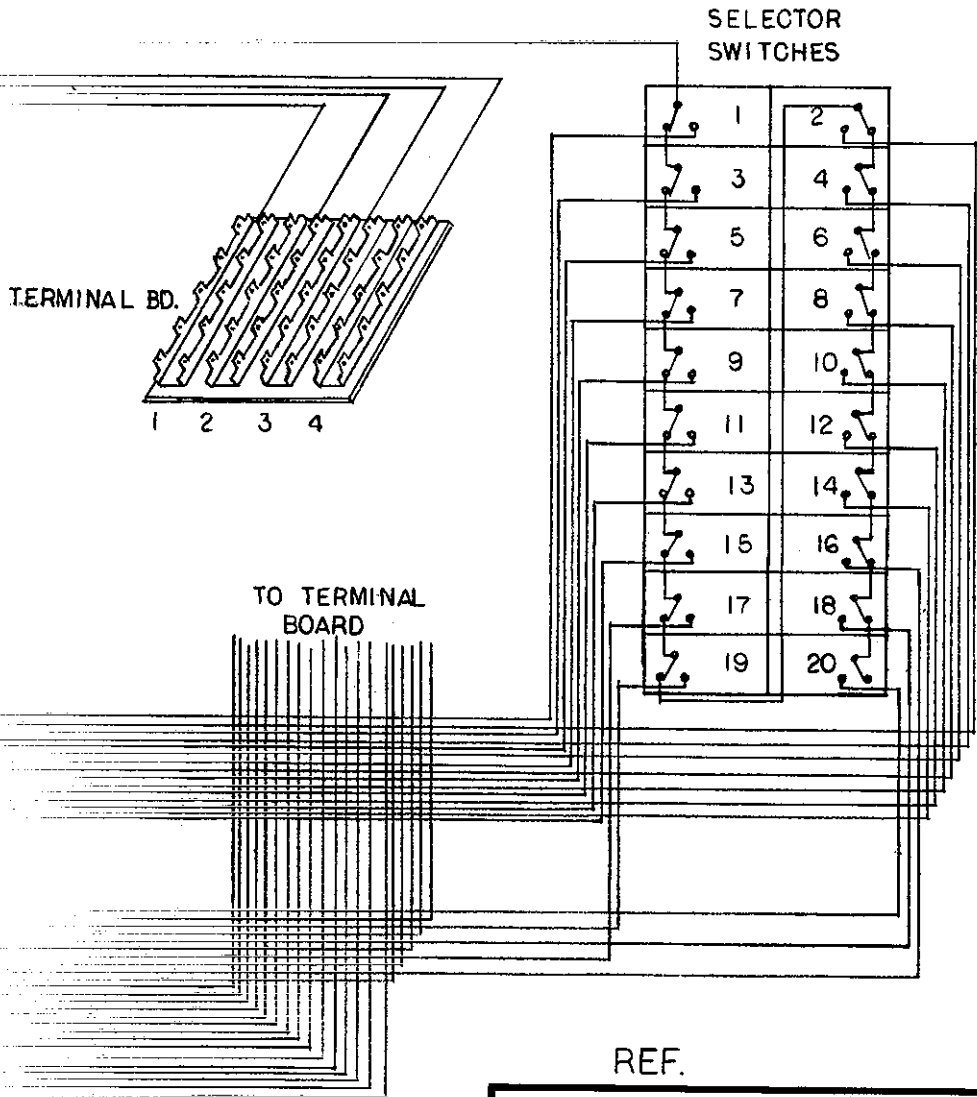
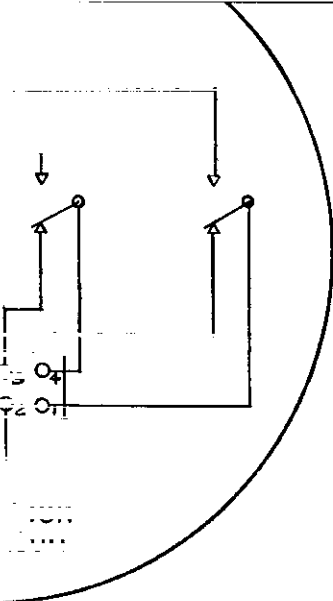

DISTRIBUTION
CODE

REF: ONLY

REF.

Polyvend CONWAY, ARKANSAS		SCALE: 1/8"	
PART NAME: SCHEMATIC - S-20		DRAWN: 7-7-78 DC	
MATERIAL: REF: HARNESS LESS RELAYS		CHECKED: mmg 11/9/78	
FINISH: #		UNSPECIFIED TOLERANCES -	
FRACTIONS: ±		DECIMALS: ±	
ANGLES: ±		PART NO. C-12682	
SHEAR SIZE: #		REV.	

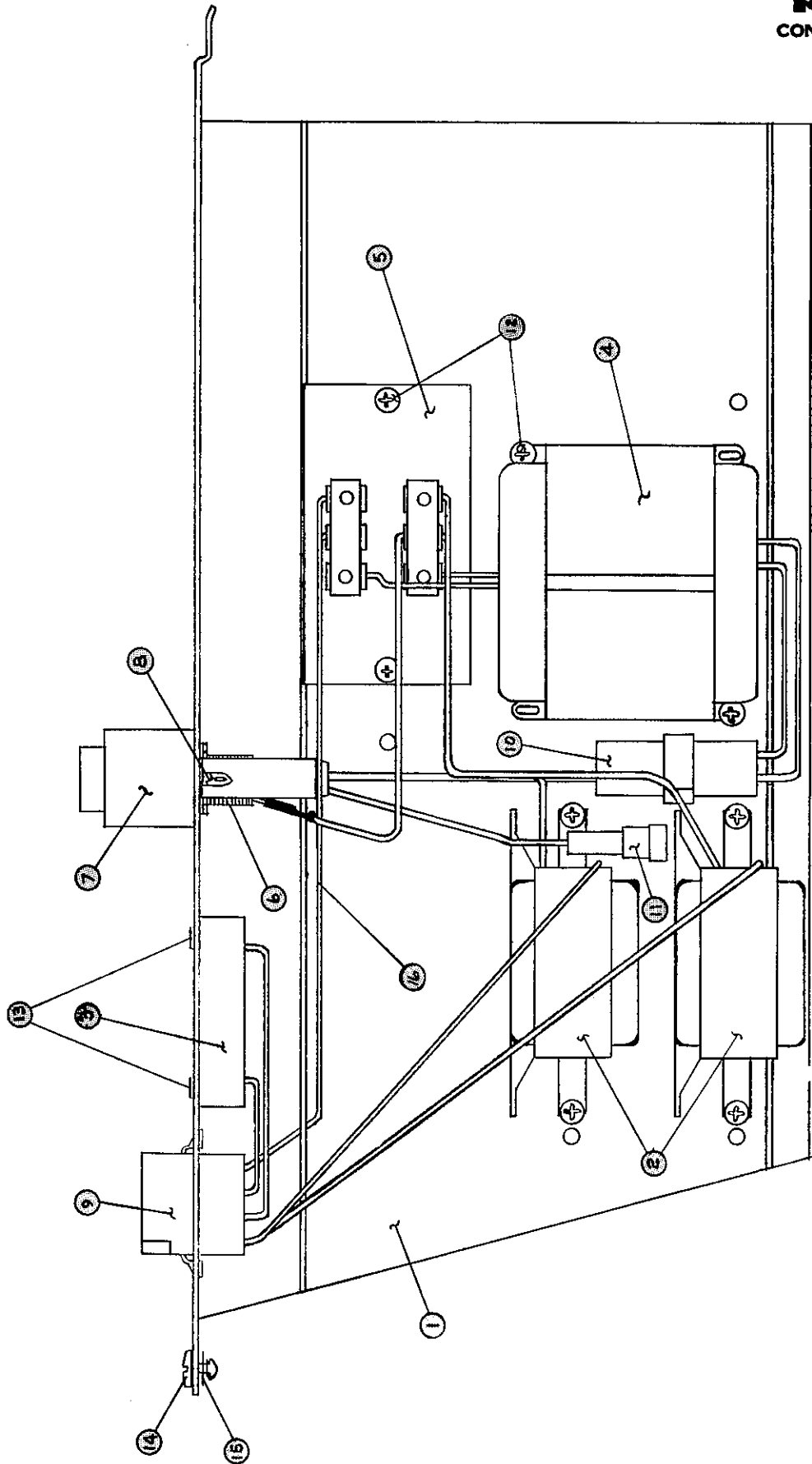

Power Panel Complete 12693

ITEM	QTY	PART NO.	DESCRIPTION
1	1	12706-01	Panel-Power
2	2	104	Ballast-115Volt
3	2	1466	Socket-Starter
4	1	1565	Transformer with receptacle
5	1	1652	Board-Terminal
6	1	996	Fuseholder - 115 Volt
7	1	1487	Fuseholder - 24 volt
8	1	1489	Clip-Mounting
9	2	4839	Receptacle - 4 pin
10	1	4844	Plug - 2 pin
11	1	4842	Plug - 1 pin
12	8	1298	Screw
13	4	302	Screw
14	1	12667	Fastener - 1/4 Turn
15	1	12668	Retainer - Fastener
*	8		Female Term.
*	2		Male Term.
*	8		.250 Quick Dis-connect
*	1	12671	Decal - Starter
*	1	12672	Decal - Fuse
16	Typ.		(Red) 20 AWG 7/28B.C. .023" PVC-SAE-GBT
*	1	222	Fuse 2 Amp (115V Holder)
*	1	.1488	Fuse 3.2 Amp (24 Volt Holder)

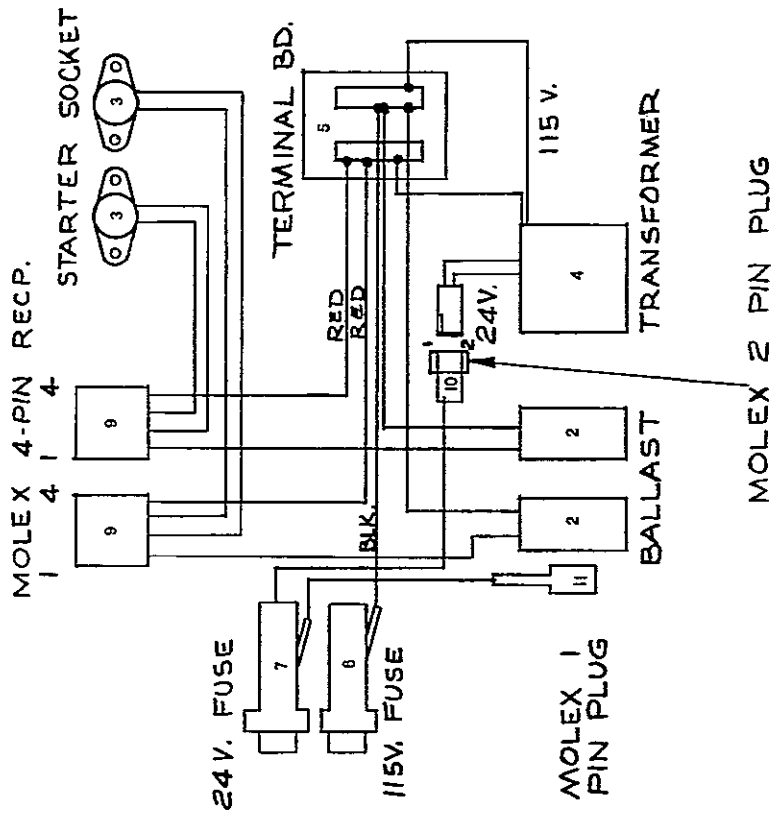

Wiring Sketch ITEMS 2,3,4,5,6,7,9,10,11

* NOT SHOWN

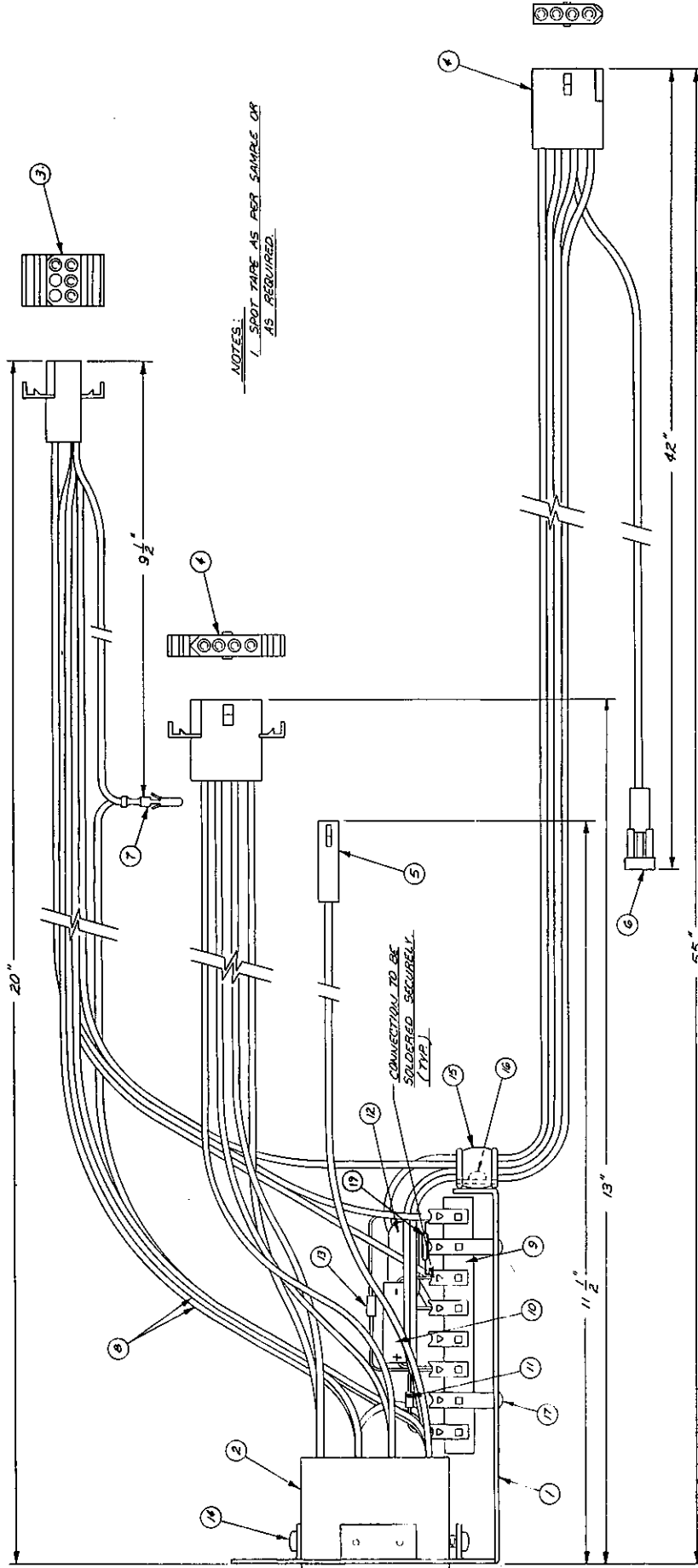

12686

Harness - Jones Plug

(Mounts to bottom of power panel)

WIRING DIAGRAM

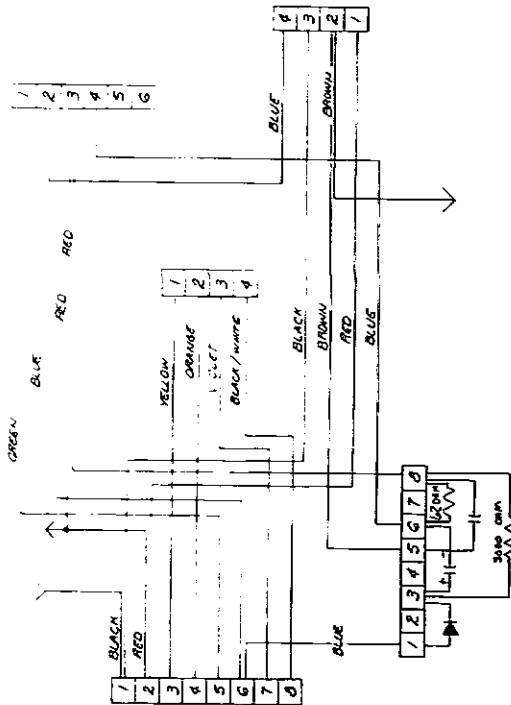

DESCRIPTION

- Bracket - Jones Plug
- Jones Plug - Molex Part No. 738
- Receptacle - Molex Part No. 1261 W/4 #1189 Fem Term.
- Receptacle - Molex Part No. 1490 W/4 #1189 Fem. Term.
- Receptacle - Molex Part No. 1619 W/1 #1189 Fem. Term.
- Plug - Molex Part No. 1619 W/1 #1190 Male Term.
- Male Term. - Molex Part No. 1190
- Wire - 20 AWG 7/28" B.C..023" PVC-SAE-GBT
- Lug - Type Terminal Strip, Allied Part No. 868-0858
- Capacitor 100 UF @ 50V (Aluminum Electrolytic)
- Diode, Part No. 1N4001
- Capacitor 0.1 UF @ 100
- Resistor - 3000 OHM, 1 Watt
- Screw, Mach. #6-32
- Clamp, Cable 3/8
- Screw, #8
- Rivit - Pop
- .016 Terminal (For #738 Recp't)
- Resistor - 62 OHM, 1/2 watt

ITEM PART NO.

- 1 12702-01
- 2
- 3
- 4
- 5
- 6
- 7
- 8
- 9
- 10
- 11
- 12
- 13
- 14 302
- 15 4332-02
- 16 1868
- 17 729
- 18 not shown
- 19

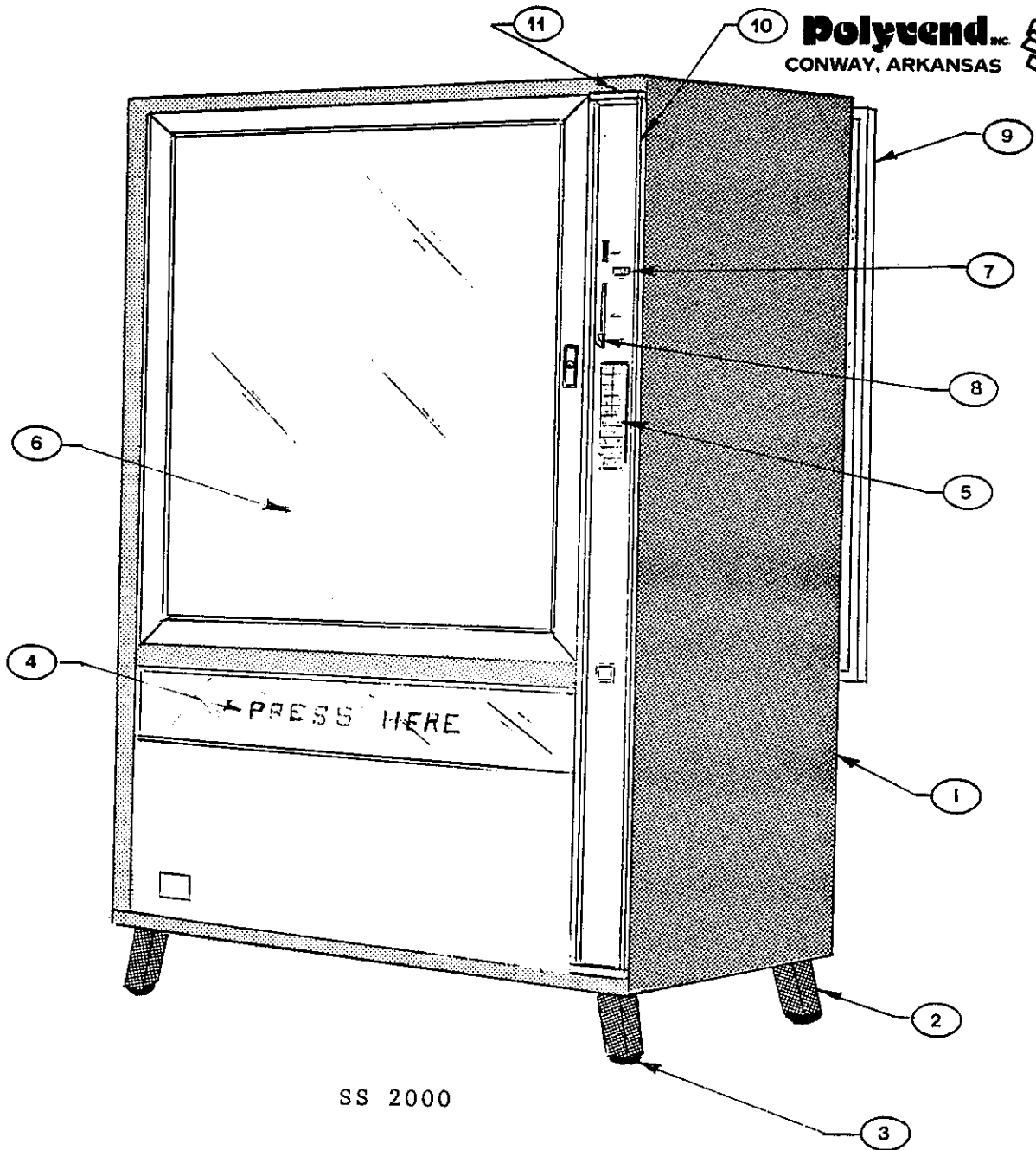

SS 2000

CABINET

INDEX	PART NO.	NOMENCLATURE
1	14214	Outer Shell (Specify Color)
2	11890	Leg Assembly
3	12766	Leg Equalizer
4	10668	Delivery Compartment Assembly
5	12681	Selector Switch Assembly
6	10669	Product Loading Door
7	1616	Indicator Light Assembly
8	10322	Reject Lever Assembly
9	10356	Rear Door Assembly (Specify Color)
10	13483	Escutcheon Plate Assembly
11	14271	Escutcheon End Cap

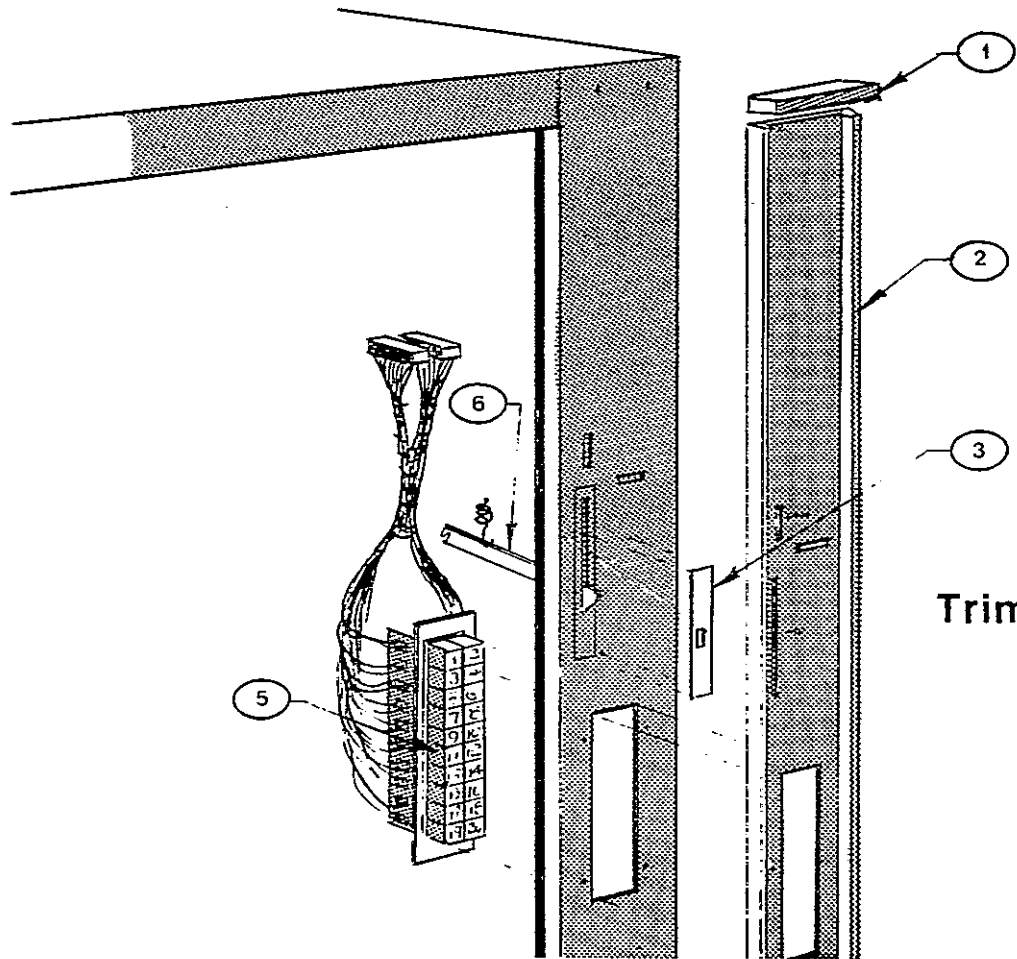

Trim Details

INDEX	PART NO.	NOMENCLATURE
1	14271	Escutcheon End Cap
2	10352	Escutcheon Plate Assembly
3	1414	Reject Lever Cover Plate
4	10342	Coin Return Cup Assembly
5	12681	Selector Switch Assembly
6	10322	Reject Lever Assembly

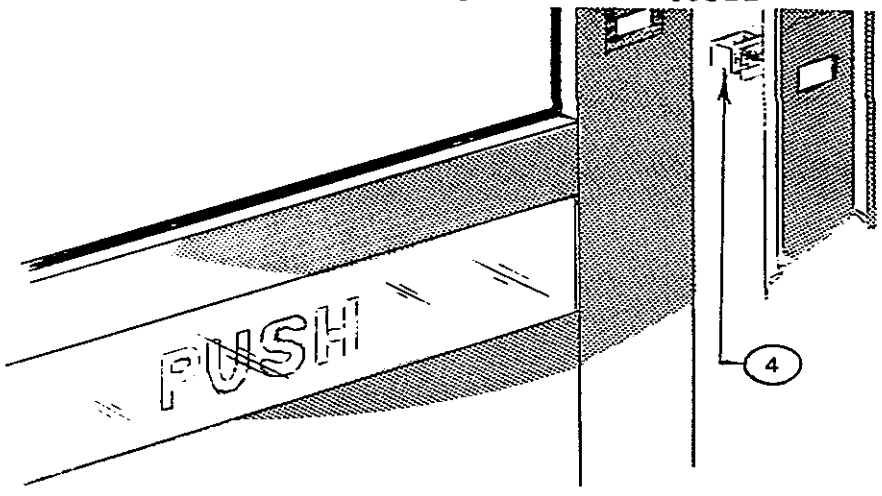

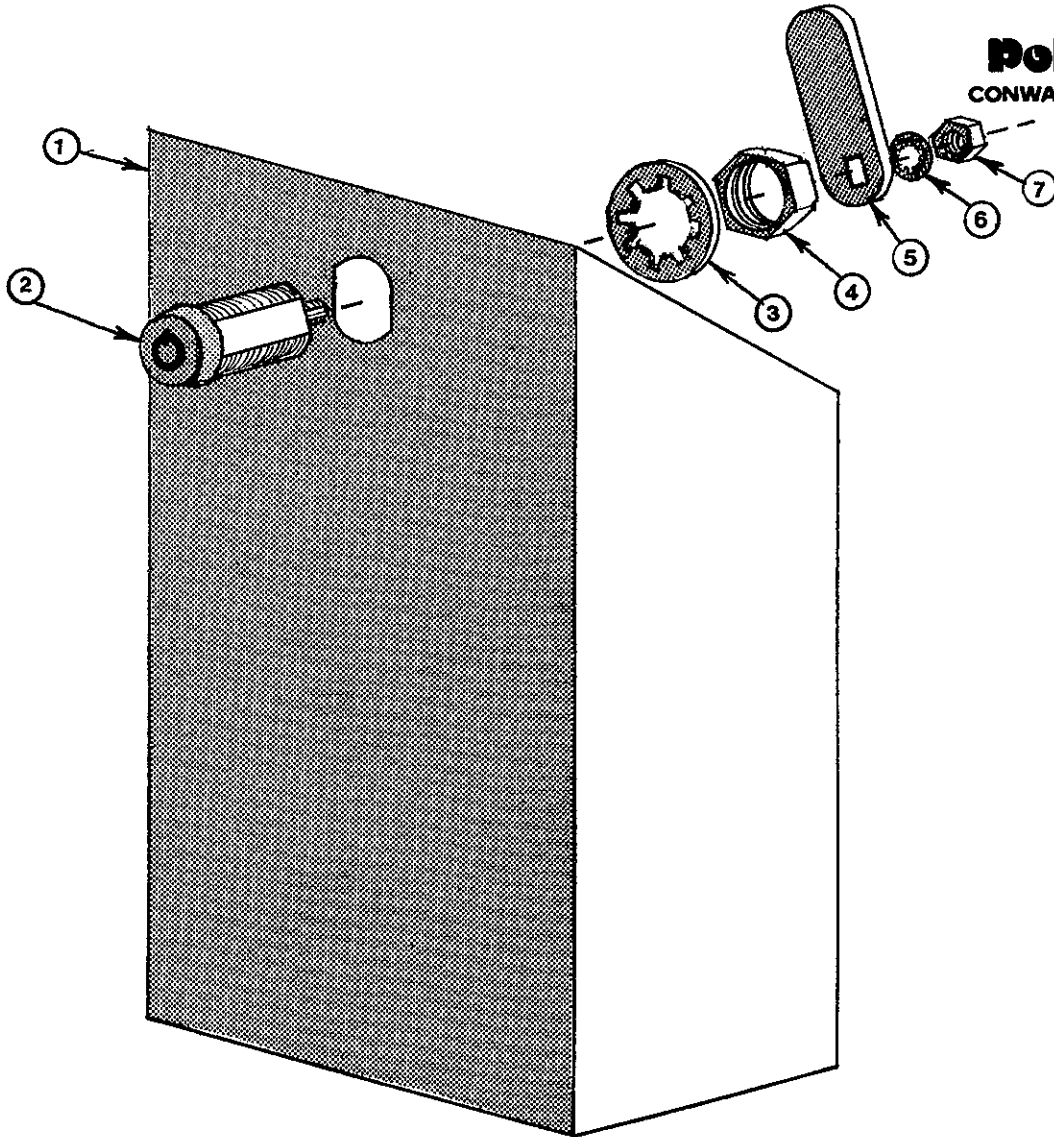

Coin Box 10665-01

&

LOCK ASSEMBLY 11186

INDEX	PART NO.	NOMENCLATURE
1	10665-01	Coin Box
2	351*	Tumbler
3	366	Lockwasher Int. Tooth 3/4"
4	1788	Hex Nut, 9/32" thick x 3/4" - 27
5	5404	Straight Cam
6	357	Lockwasher, Shakeproof 9/32"
7	358	Hex Nut 5/32" thick x 9/32" - 28

* Please specify key number when ordering. Lock is keyed -02 unless otherwise specified on order. Other keys available are -27 thru -48.

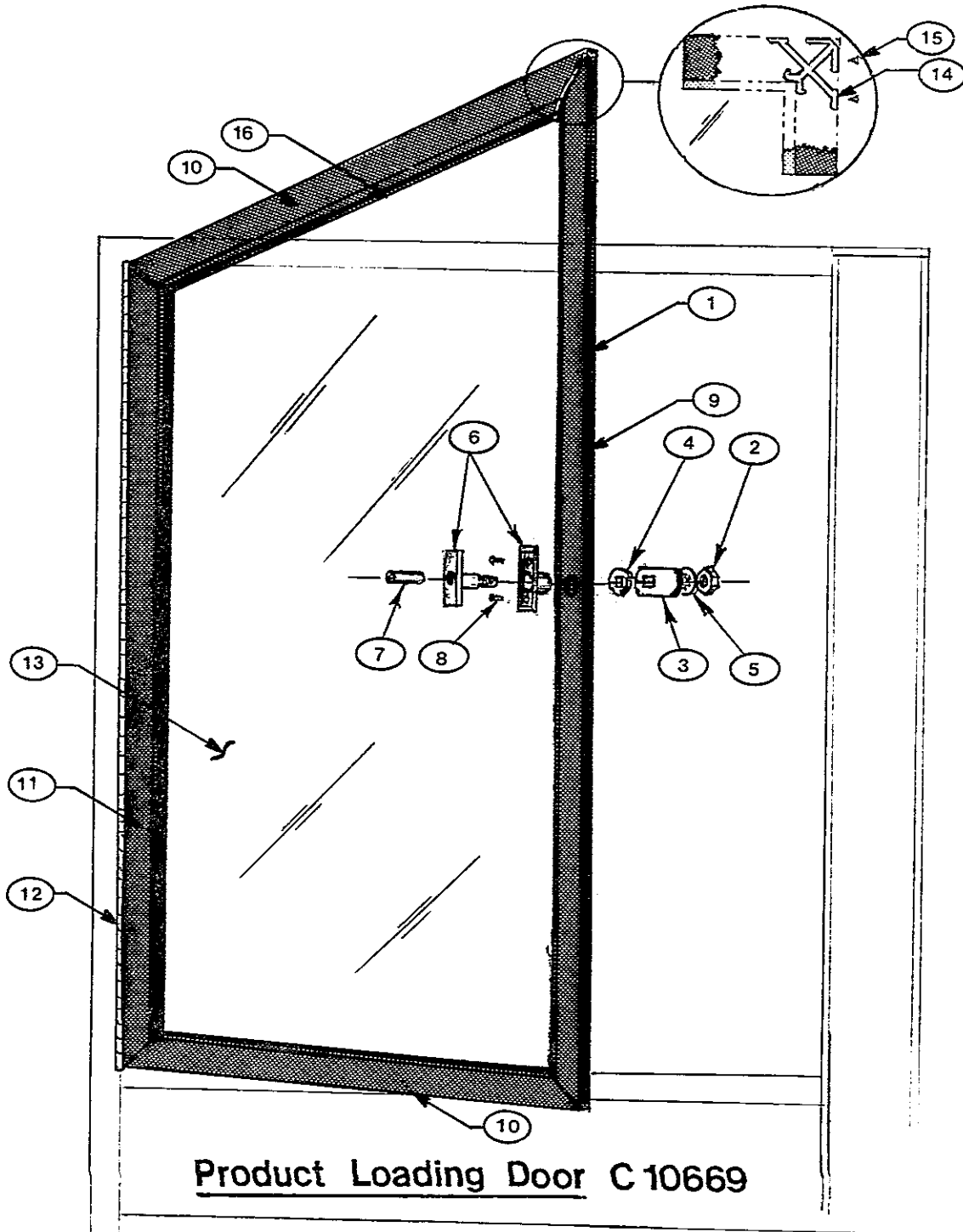

Product Loading Door C 10669

INDEX	PART NO.	NOMENCLATURE	INDEX	PART NO.	NOMENCLATURE
1	3887	Door - Product Loading	9	11594	Door Frame, Lockside
2	11538	Nut - Hex Jam	10	11595	Door Frame, Top & Bottom
3	1483	Cam	11	11596	Door Frame, Hinge Side
4	11539	Stop Cam	12	11597	Hinge, Product Door
5	1680	Lockwasher	13	1924	Glass, Tempered 3/16" Door
6	11537	Handle Assembly	14	11598	Angle, Corner Frame
7	1809 *	Cylinder - Inner	15	11599	Screws, #10 x .500 Flat Head Ct Sk
8	746	Screw	16	11600	Gasket, Vinyl - Glass/Frame (Lighter Shade)

*NOTE: Please specify key number

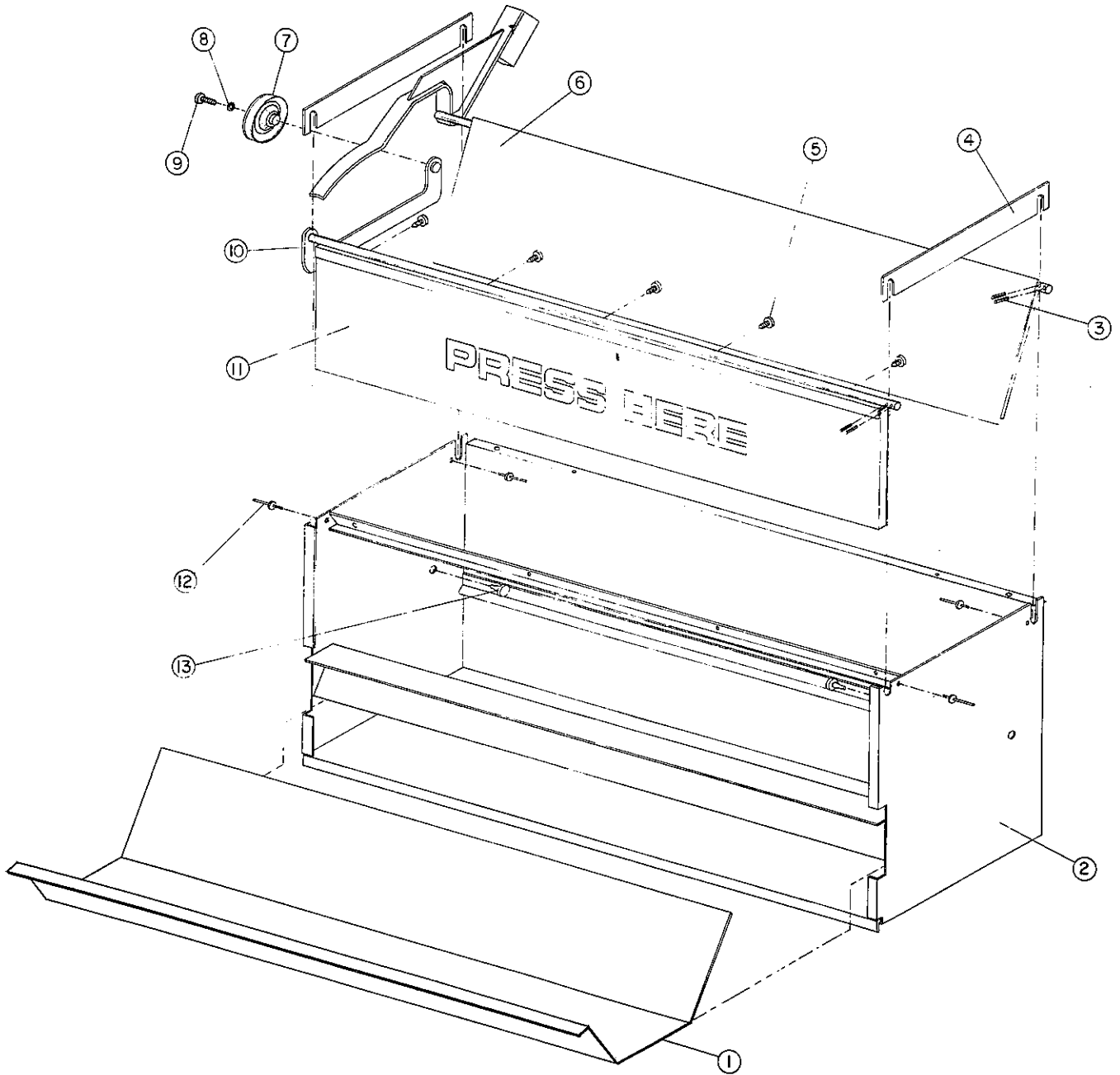

DELIVERY COMPARTMENT ASSEMBLY COMPLETE # 10668

ITEM	PART NUMBER	NOMENCLATURE
1	1394	Bottom - False
2	10662-01	Compartment W.A. - Delivery
3	1272	Pin - Roll 3/32" x 5/8"
4	1401	Retainer - Del. Comp. Door
5	1298	Screw - TP "AB" Pan #8
6	10315-01	Door W.A. - Anti-theft
7	534	Wheel - Roller Skate
8	266	Washer - Int. Tooth #8
9	681	Screw - TP "F" Pan #8
10	10335-01	Arm W.A. - Channel
11	1419-01	Door - Plexiglass
12	729	Rivet - "Pop" .125 dia. x .232
13	842	Bumper - Snap In, Rubber

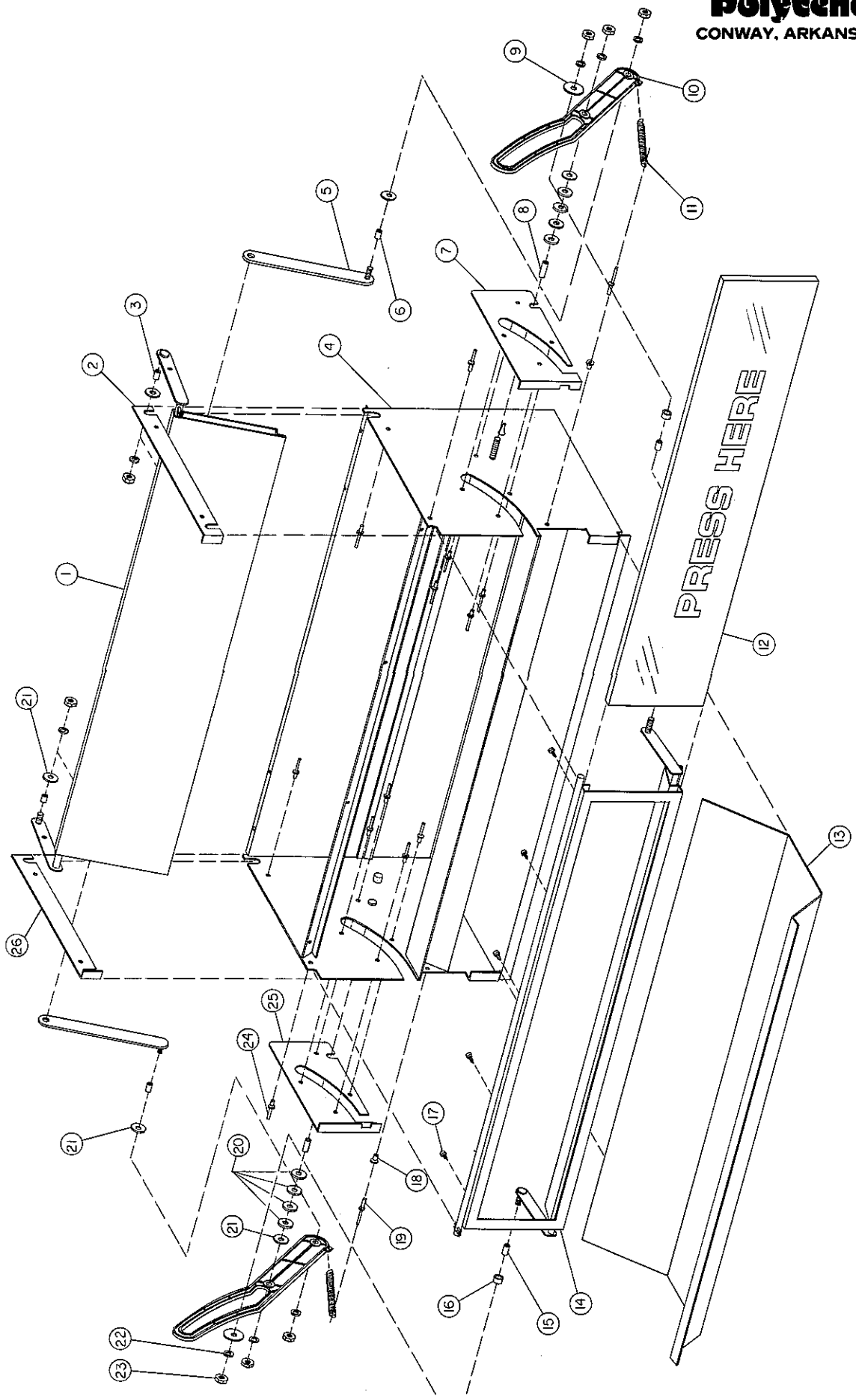

DELIVERY COMPARTMENT PARTS LIST

<u>ITEM</u>	<u>DESCRIPTION</u>	<u>PART NO.</u>	<u>QTY.</u>
1	Door WA-Anti-Theft	16129-01	1
2	Retainer-Door Rod (Right)	16141-02	1
3	Bushing-Arm	16152-01	2
4	Compt. WA-Delivery	16136-01	1
5	Arm WA-Connecting	16139-01	2
6	Bushing-Arm	16152-02	2
7	Retainer Pivot Arm (Right)	16142-02	1
8	Bushing-Arm	16152-03	2
9	Washer-Flat	16154	2
10	Arm-Plastic, Del. Compt.	16143	2
11	Spring-	611	2
12	Door-Del.	16138-01	1
13	Bottom-False	16137	1
14	Door WA-Push	16151-04	1
15	Bushing-Bushing	16153	2
16	Bushing-Bronze	14055	2
17	Screw-TP AB Pan #2	1298	5
18	Spacer-Detent Spring	1745	2
19	Rivet-Pop	1642	2
20	Washer-5/16 I.D. 3/4 O.D.	13398	8
21	Washer-5/16 I.D. 3/4 O.D.	13412	6
22	Lock Washer-Split	2386	8
23	Nut-Hex	2385	8
24	Rivet-Pop	729	12
25	Retainer-Pivet Arm (Left)	16142-01	1
26	Retainer-Door Rod (Left)	16141-01	1

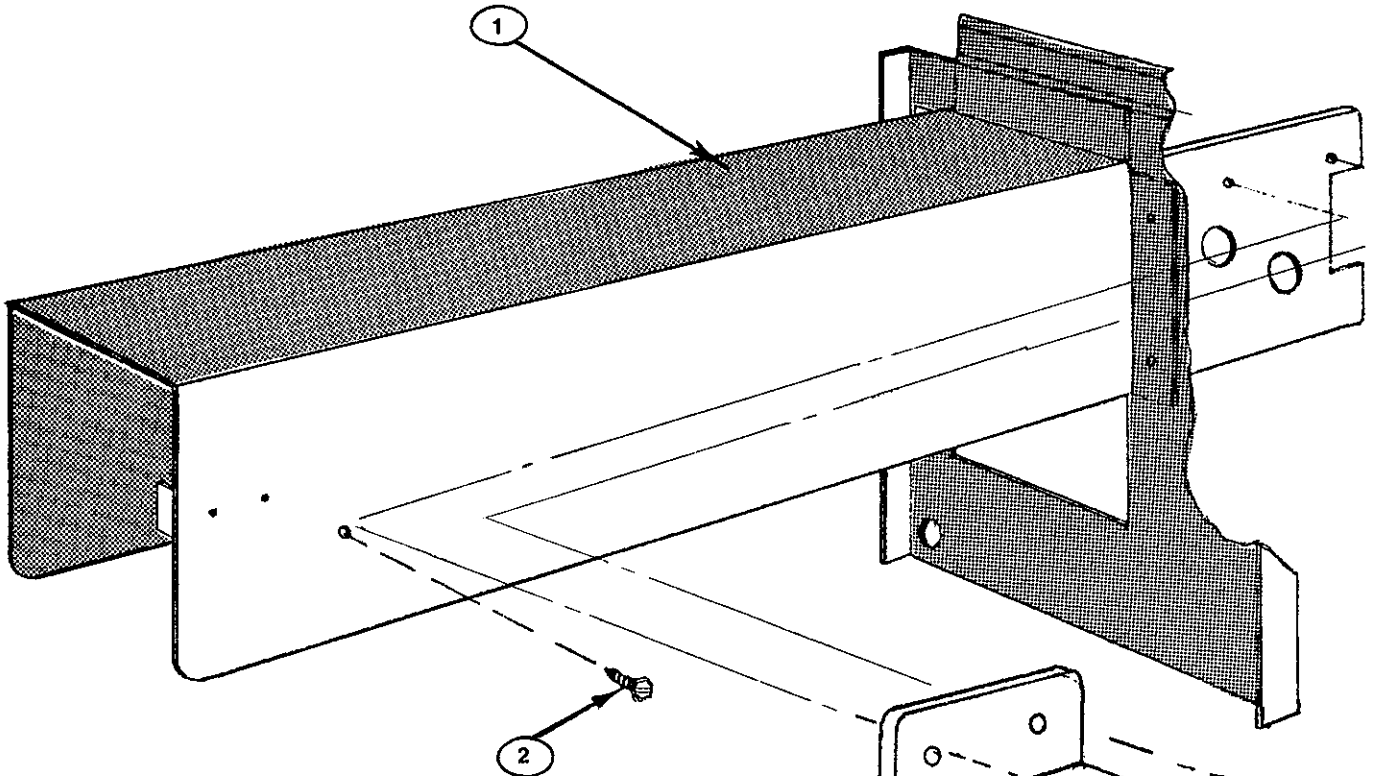

MODULE ARM COMPLETE 12698-02

INDEX	PART NO.	NOMENCLATURE
1	10483-01	Module Arm
2	689	Screw 8 x 3/8" "Hex"
3	12569-02	Motor Assembly - Complete
4	1868	Screw - #8-32 x 1/4 Type B Pan Hd Ph Recess ZPYD

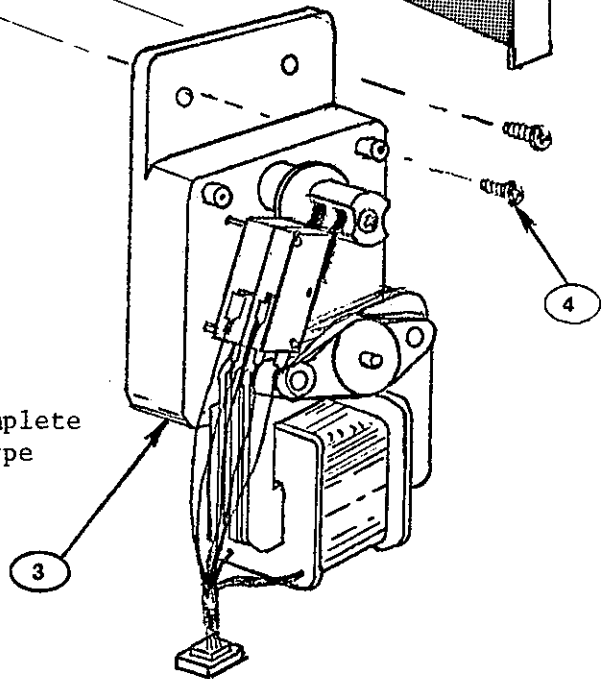

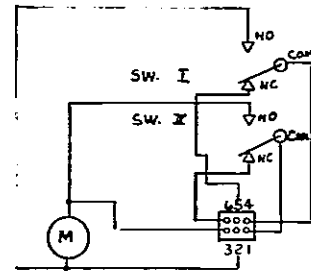
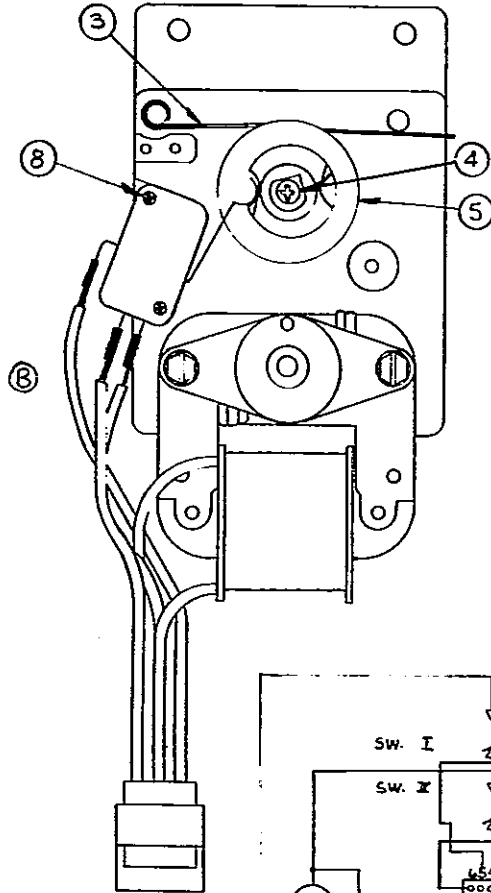
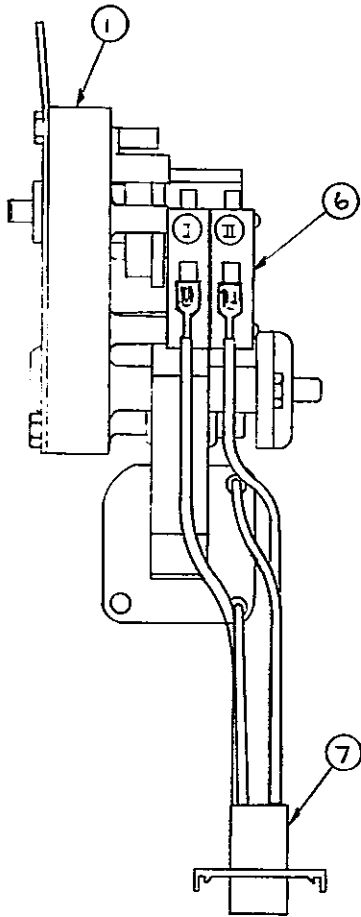

Wiring Diagram

MOTOR ASSEMBLY COMPLETE 12569-02

ITEM	PART NUMBER	QTY.	NOMENCLATURE
1	1789	1	Motor - Gear Assembly
2	*	*	(Included with Item 7) Connectors
3	1743	1	Spring - Detent
4	12662	1	Screw
5	12537	1	Cam - 180°
6	12660	2	Switch - Snap
7	12661	1	Wiring Harness
8	12754	2	Screw #4-40 x 1"

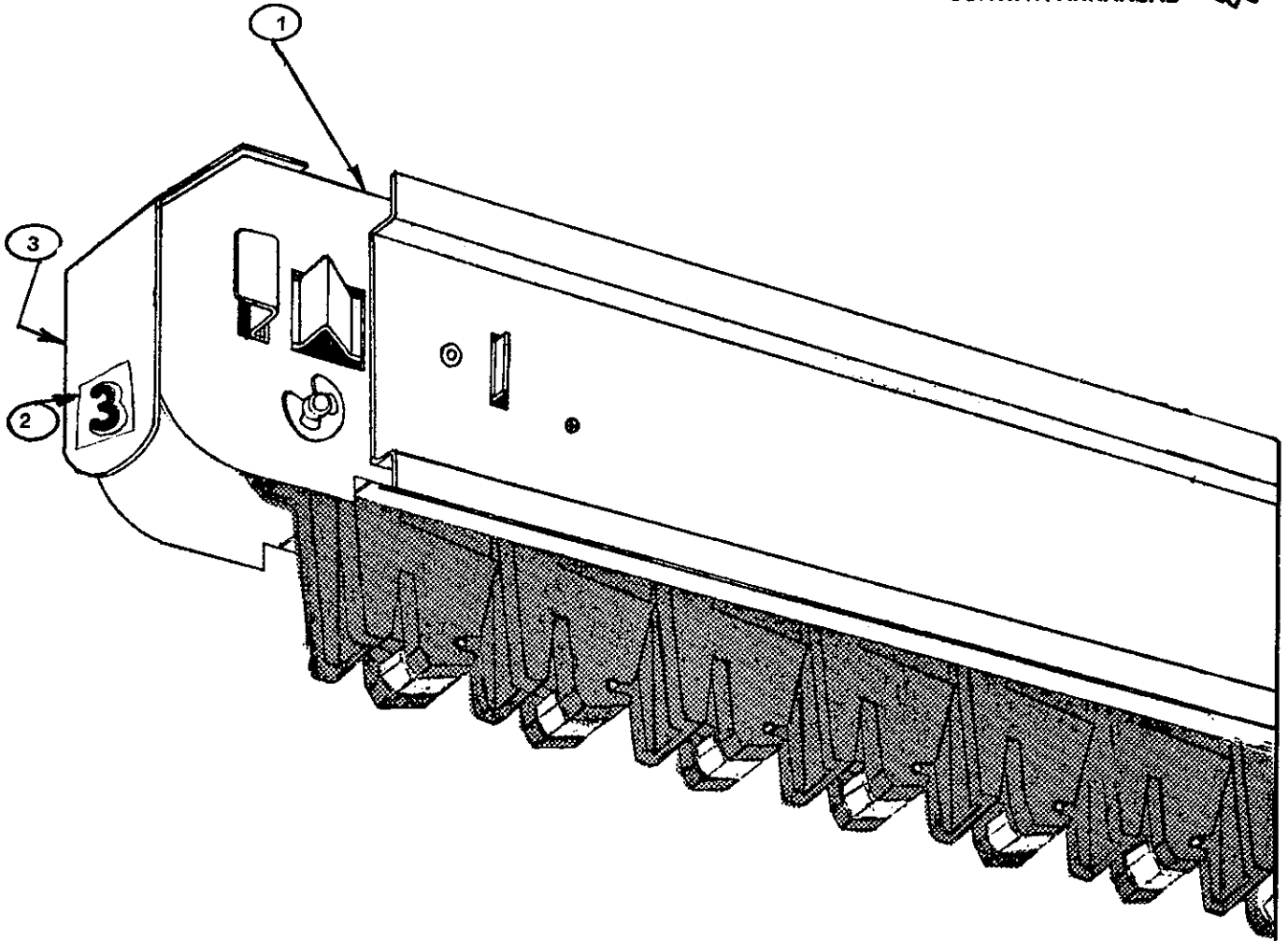

RACK MODULE ASSEMBLY

ITEM	PART NUMBER	NOMENCLATURE
1	10484	Rack Module Assembly
2	1790	Decals - Selection Number (Complete set numbers 1 thru 20)
3	12287-01	Tab and Stripper Assembly - Plastic (Old Style)
	13597-01	Tab and Stripper Assembly - Plastic (New Style)

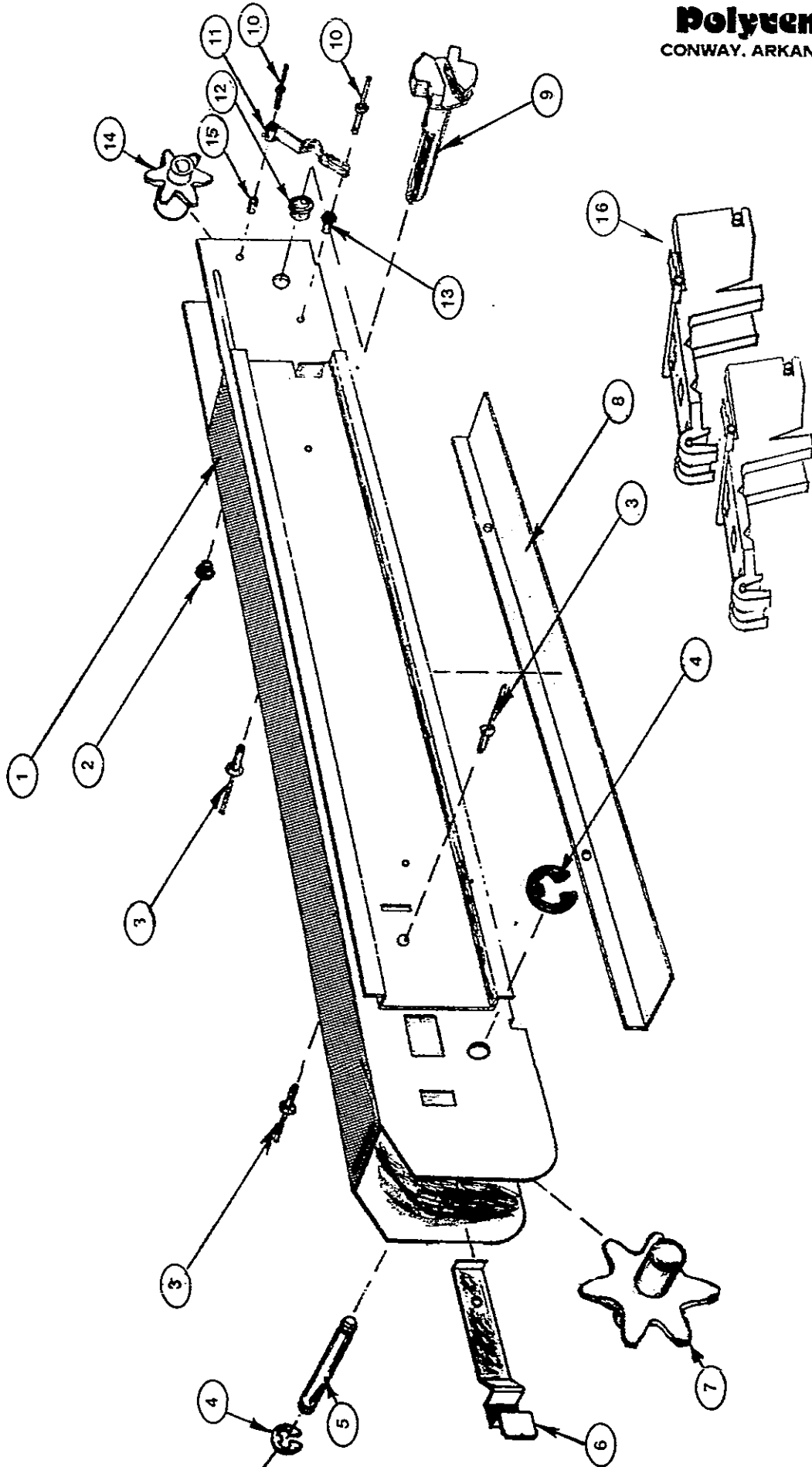

RACK MODULE - 10484

NOMENCLATURE

INDEX	PART NO.	NOMENCLATURE
1	10495-01	Slide & Module Assembly
2	730	Bushing
3	729	"Pop" Rivet SD-42-BS
4	2559	"E" Ring, Tru Arc
5	2558	Front Sprocket Shaft
6	1744	Spring Lock
7	2565	Sprocket - Front
8	1774	Chain Guide
9	1741	Sprocket Shaft - Rear
10	1642	"Pop" Rivet SD-45-BS
11	1743	Spring, Rear Sprocket, Detent
12	1178	Bearing Bushing
13	1745	Spacer - Detent, Spring "T"
14	2563	Sprocket - Rear
15	1869	Spacer - Detent, Spring "Plain"
16	10487	Chain Asy., Complete - Wedge

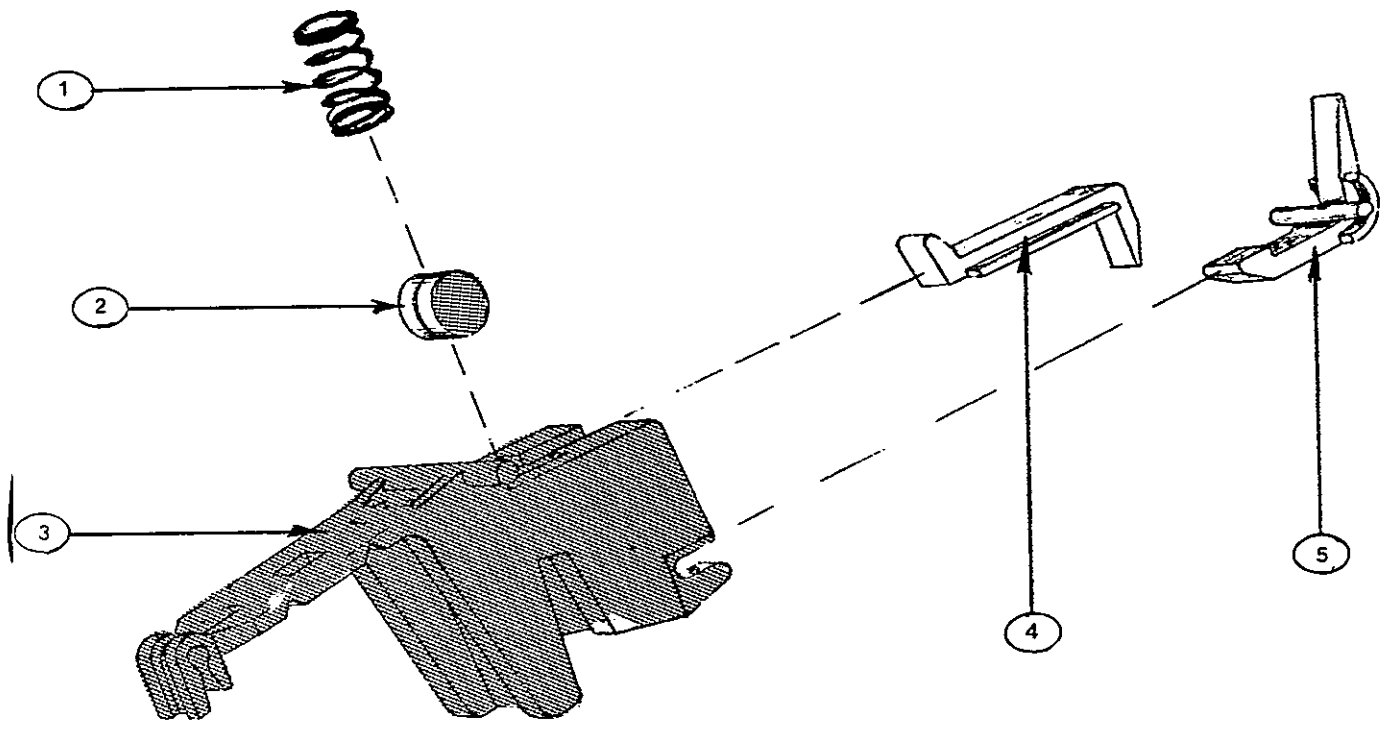

CHAIN SEGMENT ASSEMBLY -10416

INDEX	PART NO.	NOMENCLATURE
1	-1720	Spring, Compression
2	-1754	Wedge, Cylindrical (2 req)
3	-1723	Chain Housing Segment
4	-1717	Slide
5	-1719	Lifter, Cylinder

RACK MODULE - 10438

ITEM	PART NUMBER	NOMENCLATURE
1	10495-01	Slide & Module Assembly
2	730	Bushing
3	729	"Pop" Rivet SD-42-BS
4	2559	"E" Ring, Tru Arc
5	2558	Front Sprocket Shaft
6	1744	Spring Lock
7	2565	Sprocket - Front
8	4963	Chain Guide
9	1741	Sprocket Shaft - Rear
10	1642	"Pop" Rivet SD-45-BS
11	1743	Spring. Rear Sprocket, Detent
12	1178	Bearing Bushing
13	1745	Spacer - Detent, Spring - "T"
14	2563	Sprocket - Rear
15	1869	Spacer, Detent Spring "Plain"
16	10348	Hook Chain Assembly

ITEM	PART NUMBER	NOMENCLATURE
17	1498	Chain Hook Link -- 28 required
18	1500	Chain Plain Link -- 28 required
19	1499	Chain Retainer Link -- 28 required

NOTE: Item 20 is not included in 10438
 20 12287-01 Number Tab - Plastic (Old Style)
 13597-01 Number Tab - Plastic (New Style)



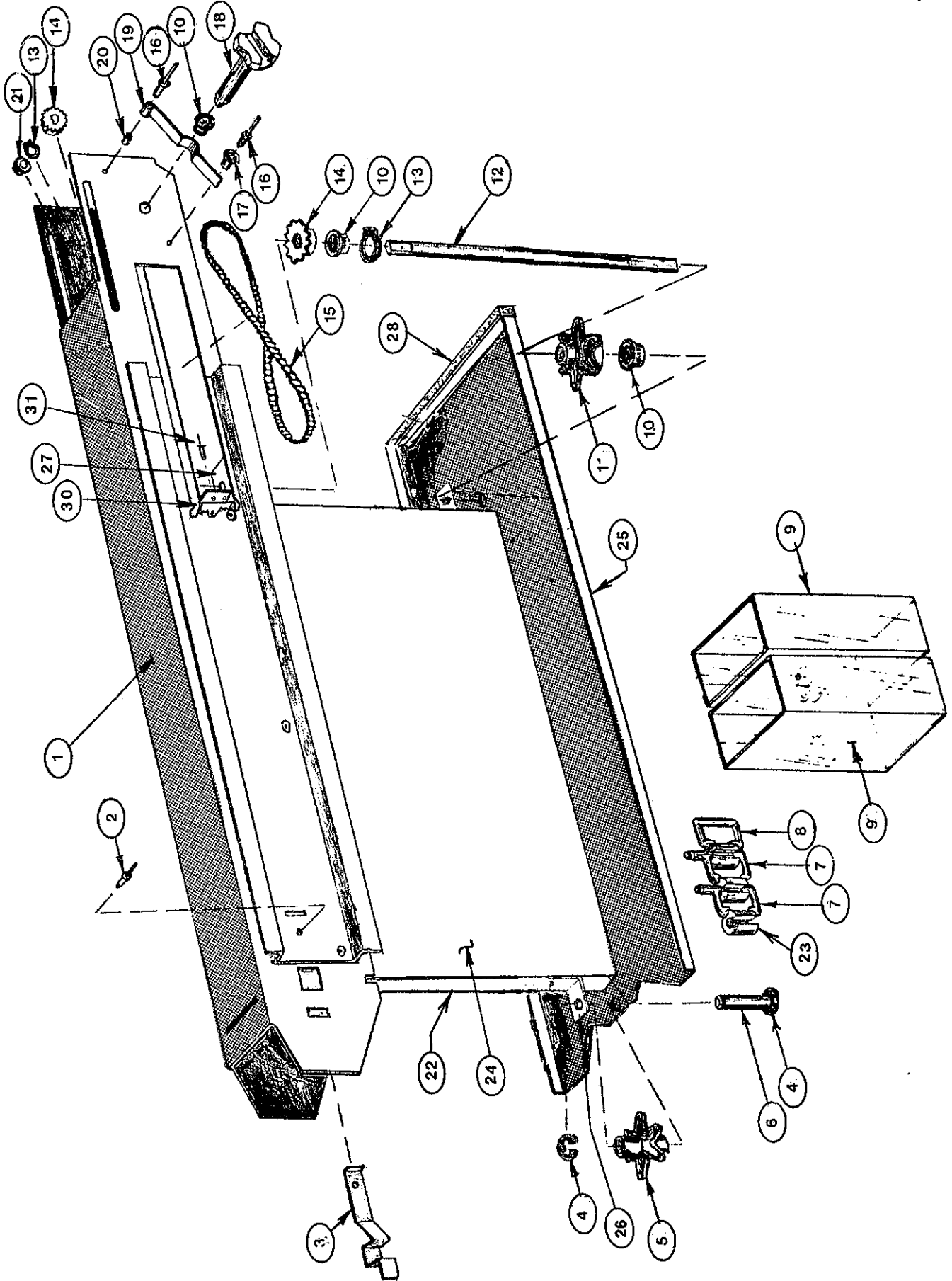

CANDY MODULE -10935



INDEX	PART NO.	NOMENCLATURE
1	10478-01	Candy Slide and Module
2	729	"Pop" Rivet SD-42-BS
3	1744	Spring Lock
4	2559	"E" Ring, Tru Arc
5	2565	Front Sprocket
6	2558	Front Sprocket Shaft
7	1945	Cup Retainer Link
8	1946	Plain Link
9	4886	Dispensing Cup
10	1178	Bearing Bushing
11	2563	Rear Sprocket
12	1939	Vertical Shaft
13	2225	Gripring
14	1927	Drive Sprocket
15	1928-01	Ladder Chain
16	1642	"Pop" Rivet SD-45-BS
17	1745	Spacer - Detent Spring "(T)"
18	1741	Rear Sprocket Shaft
19	1743	Rear Sprocket Detent Spring
20	1869	Spacer-Detent Spring (Plain)
21	730	Bushing
22	2321-01	Divider Left Side
23	10526	Chain Asy - Complete
24	2320-01	Divider - Right Side
25	4893	Bottom - Candy Module
26	1935-01	Retainer - Front Shaft
27	1936-01	Retainer - Rear Shaft
28	810-01	Stripping - Neoprene
30	4846	Plate - Rivet Reinforcement
31	4948	Rivet - Pop.125D x .294
32	1298	Screw - TP "AB" #8

TROUBLE SHOOTING

- MACHINE WILL NOT ACCEPT COINS: Remove acceptor/rejector to visually inspect 5¢/10¢ blocking fingers in coin changer.
 - 5¢/10¢ blocking fingers are magnetically retracted:
 - Be sure the machine is level.
 - Be sure the changer is properly installed.
 - Be sure blocking fingers are adjusted properly - not protruding into the acceptor/rejector.
 - Acceptor/rejector needs cleaning or adjustment, clean, repair, or replace.
 - 5¢/10¢ or 25¢ blocking fingers are not magnetically retracted:
 - Make sure machine is plugged into 115 volt outlet.
(Are fluorescent lamps on - check 2 amp fuse)
 - Make sure changer Jones Plug is securely connected.
 - Check manual payout on changer. If it does not operate, check red cap fuse. If blown, check for short or ground on 24 volt circuit. Transformer may be defective.
 - Check to see that each module arm is pushed in all the way so as not to lock a motor in cycle.
 - Check series circuit that runs through all the outer switches on the dispense motors:
 - Manually pull #20 dispensing chain forward by grasping several segments with both hands.
 - If it fails to electrically pick up and complete a cycle; Check wire continuity from Pin #1 of Changer Jones plug receptacle to pin #1 of Dispense Motor #20. Also check motor assembly #20 for proper switch operation and connection.
 - If #20 electrically picks up and cycles; repeat pull test for dispenser #1.
 - If #1 fails to pick up electrically; the series circuit is broken between #20 and #1. Locate break by continuing pull test through the circuit in descending number order (#19 thru #1) until the first dead position is found.

Either this "dead" dispenser motor assembly or the last operable assembly is faulty.

- If #1 picks up electrically; check wire continuity from pin #6 of motor #1 to pin #6 of the Changer Jones Plug receptacle.

NOTE: The direct descending order (#20 thru #1) for the motor series circuit is different from previous WS-20 machines.

- If all the above check good, the coin changer is defective.
- MACHINE WILL ACCEPT COINS BUT.....
 - No selection can be made.
 - Check for coins lodged in coin path of changer.
 - Check series circuit that runs through all the outer switches on the dispense motors:
 - Manually pull #20 dispensing chain forward by grasping several segments with both hands.
 - If it fails to electrically pick up and complete a cycle; check wire continuity from pin #2 of Changer Jones Plug receptacle to pin #4 of Dispense Motor #20. Also check Motor Assembly #20 for proper switch operation and connection.
 - If #20 electrically picks up and cycles; repeat pull test for dispenser #1.
 - If #1 fails to pick up electrically; the series circuit is broken between #20 and #1. Locate break by continuing pull test through the circuit in descending number order (#19 thru #1) until the first dead position is found. Either this "dead" dispenser motor assembly or the last operable assembly is faulty.
 - If #1 picks up electrically; check wire continuity from pin #5 of motor #1 to position #1 of selector switch.

NOTE: The direct descending order (#20 thru #1) for the motor series circuit is different from previous WS-20 machines.

- If all the above check good, the coin changer is defective.
- Only some selections can be made.
- Changer must be a 24 volt 4-price unit.



- Identify defective selections by number and determine if a dead price level in changer is cause of failure. Also be sure of vend price setting for that level.
- Check for defective selector switch assembly. The selector switch is wired in series starting at position #1 and running down the left side thru the odd numbers. A jumper then connects to position #2 and the series circuit runs down the right side thru the even numbers. A defective selector switch is indicated when a sequence of selections in this series do not operate.

EXAMPLE: Selection #1, #3, #5, and #7 can be made but the remaining selections can not. The selector switch is defective between positions #7 and #9.

- Check for good and proper connection of price setting motor leads at terminal board above changer.
- MACHINE WILL VEND CONTINUOUSLY.....
 - Determine selections that are vending continuously.
 - If selections are controlled by a common price level of changer - replace changer.
 - If free-vending selections have no common connection by price level - dispense motor assembly is probably defective.
- MACHINE WILL ACCEPT CERTAIN COINS BUT NOT OTHERS (ALWAYS A COIN MECHANISM PROBLEM).....
 - Will not accept quarters.
 - Check to see if coin tubes have sufficient coins to retract 25¢ blocking finger.
 - If coin tubes are full and finger is not retracted, check for loose connection, burned out electromagnetic coil, or defective tube switch.
 - Check to see if the 25¢ blocking finger is adjusted so that when magnetically pulled in, the tip is clear of the rejector/acceptor.
 - If none of the above, clean, adjust, or replace, acceptor/rejector.
 - Will not accept nickels and dimes.
 - Check 5¢/10¢ blocking fingers.
 - If fingers are retracted, check to see if the fingers are adjusted so that when magnetically pulled in, the tips clear the rejector/acceptor.
 - If not the above; clean, adjust, or replace acceptor.
 - If not retracted, check for loose connection, or a burned out electromagnetic coil.

POLYVEND, INC.

SS-2000 TWENTY SELECTION SNACK MACHINE

PART NUMBER	DESCRIPTION
10335-01	ARM WA-CHANNEL
12406-02	ARM WA-DOOR
10483-01	ARM WA-MODULE
12698-02	ARM-ASY-MODULE
104	BALLAST-115V
10665-01	BANK WA-COIN
3193	BOARD ASY-TERMINAL
1477-01	BOTTOM-DISPLAY
1394	BOTTOM-FALSE
1381-01	BRKT-LAMP
1416-01	BRKT-REJECT LEV MTG
1440	BRKT-SELECTOR SWITCH
326	BUMPER-SNAP IN
842	BUMPER-SNAP IN RUBR
1178	BUSHING-BEARING
1322	BUSHING-SB-2000
730	BUSHING-SB-437-5
1435	BUSHING-SHOULDER
2438	BUSHING-SR-6N3-4
14271-01	CAP-ESCUTCH END
2236	CAP-TRIM END
4959	CASTING-COIN INSERT
10487	CHAIN-WEDGE, 28 LINK
11765	CHANNEL WA-BOTTOM
10319-01	CHUTE WA-UPPER COIN
1489	CLIP-FUSE HOLDER MTG
10662-01	COMPT ASY-DEL
10668	COMPT ASY-DEL COMPLETE
1473	CORD-SERVICE 13 FT
8436-01	COVER-WIRE
10342	CUP ASY-COIN RETURN
10230	CUP WA-COIN RETURN
4886	CUP-DISPENSING
1293-12	DATA PLATE-W-20-4
12672	DECAL-FUSE
1790	DECAL-SEL NUMBER
12671	DECAL-STARTERS
11540	DECAL-WARNING
8571-04	DECAL-25C PRICE
8571-05	DECAL-30C PRICE
8571-06	DECAL-35C PRICE
8571-07	DECAL-40C PRICE

PART NUMBER	DESCRIPTION
1479-01	DEFLECTOR-LH
1439-01	DEFLECTOR-RH
10356	DOOR ASY-REAR
10315-01	DOOR WA-ANTI-THEFT
577	DOOR-COIN RETURN CUP
1419-01	DOOR-PLEXIGLAS
3887	DOOR-SERVICE WS-20
1383-02	DOOR-SHELL REAR
12705	DOOR-SLIDING
12704-01	DOOR-W.A. SLIDING
12766	EQUALIZER-LEG E SLOT
549	EXTENSION-REJ LEVER
13483	EXTRUSION-ESCU.
12667	FASTENER-1/4 TURN
10340	FIXTURE ASY-LAMP
1488	FUSE-GMQ 3
222	FUSE-MDL 2
1924	GLASS-DOOR W20
1774	GUIDE-CHAIN
12673	HARNESS-ADAPTER 20'S
12666	HARNESS-CORRECT CHG
12686	HARNESS-J.P. SS15-20
1520	HARNESS-LAMP
1629	HARNESS-LAMP, W20
12684	HARNESS-MAIN 20'S
12674	HARNESS-PRICE SS20
12675	HARNESS-SUB-MAIN
996	HOLDER-FUSE
1487	HOLDER-FUSE HLQ 3
8655	HOPPER ASY-COIN W20
10666	HOUSING WA-COIN BOX
3649	INSERT-INSTRUCTION
10955	KIT-20 WK CANDY MOD
1804	LABEL-U.L.
1616	LAMP-CORRECT CHANGE
759	LAMP-F18T8/CW/K30
11890	LEG ASY-SHELL
10327	LEG WA-FNT, BACK & PLT
10338-01	LEG WA-PLATE
10322-01	LEVER WA-REJECT
10345	LOCK-REAR DR, 20'S
1744	LOCK-SPRING
1490	LOCK/SVC DR, 20'S
10484	MODULE WA-RACK
12569-02	MOTOR-CHIP MCH 4P

PART NUMBER	DESCRIPTION
533	NUT-WELD #8-32
1296	NUT-WELD #8-32
263	NUT-WELD 3/8-16
12711-01	PANEL WA-R.H. INNER
13914	PANEL-MODULE MTG
12693	PANEL-POWER
12709	PANEL-R.H. INNER
1272	PIN-ROLL 3/32X5/8
1747	PLATE-MODULE FACE
1484	PLATE-NAME, POLYVEND
1302	PLATE-PATENT NOTICE
1414	PLATE-REJ LEVER COV
12701	PLATE-UPPER TRACK
4844	PLUG-2 PIN
1705	REINF-ANTITFT DR ROD
1401	RETAINER-DEL DOOR
1597	RETAINER-FALSE BTM
12668	RETAINER-SPLIT RING
1943-01	RETAINER-TRIM
1943-02	RETAINER-TRIM
1943-03	RETAINER-TRIM
2559	RING-E, 5133-25
729	RIVET-POP 125DX232
1642	RIVET-POP 125DX419
766	SCREEN-FBRGLAS 18X16
766-01	SCREEN-REAR
766-02	SCREEN-SHELL BTM
1478	SCREW-MCH HEX 3/8
302	SCREW-MCH PAN #6
1715	SCREW-SEMS PAN #8
2614	SCREW-TP A PAN #8
1298	SCREW-TP AB PAN #8
1868	SCREW TP PAN #8
689	SCREW-TP SF HEX #8
638	SCREW-TP 23 FLT #8
863	SCREW-TP 23 PAN #4
11894	SCREW-TP 23 PAN #8
13220	SCREW-8-32 I F
2558	SHAFT-FRONT SPROCKET
1741	SHAFT-REAR SPROCKET
801	SOCKET-LAMP HOLDER
1466	SOCKET-STARTER
1745	SPACER-DETENT SPRING
1869	SPACER-DETENT SPRING

POLYVEND, INC.

SS-2000 TWENTY SELECTION SNACK MACHINE

PART NUMBER	DESCRIPTION
11969-01	SPACER-REAR DOOR
827	SPACER-REJECT LEVER
1743	SPRING-DETENT
84	SPRING-EXTN 1 3/4
2565	SPROCKET-FRONT
2563	SPROCKET-REAR
2607	STARTER-FS 25
545	STRAP-HARNESS
1751	STRIKER-LATCH
810-00	STRIPPING-NEOPRENE
2422	SUPPORT-MODULE PKG
12681	SWITCH-SELECTOR
12703-00	TRACK W.A.-UPPER
12703-01	TRACK W.A.-UPPER
10331	TRACK W.A.-LOWER
12545-01	TRACK-DBL: 21 1/32
1565	TRANSFORMER-75VA
1470-00	TRIM-DEL COMPT W20
1470-01	TRIM-DEL COMPT W20
1950	TRIM-J STRIP
266	WASHER-INT TH #8
534	WHEEL-ROLLER SKATE
1709	WIRE-GROUND
5365	WIRE-GROUND

TERMS NET 30

MINIMUM NET ORDER \$10.00
 ALL PRICES SUBJECT TO CHANGE

F.O.B. FACTORY

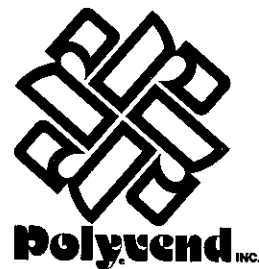

Polyvend INC.

South German Lane
Conway, Ark. 72032 USA
Phone (501) 327-1301

Polyvend INT.

South German Lane
Conway, Ark. 72032 USA
Phone (501) 327-1301
Telex 536237 USA

Polyvend LTD.

Station Lane
Whitney, Oxon, OX 86 BU England
Phone 0993-74601
Telex 837534